

# Tubes and Fittings

FOR HIGH PURITY GAS SYSTEMS

We offer a complete program of stainless steel tubes and fittings for high purity gassystems

2023

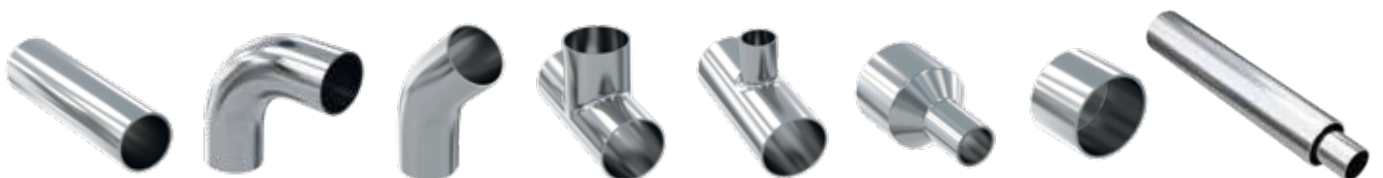

## PQE

Inside electropolished Tubes and Fittings for transport of Ultra High Purity Gases used in semiconductor and microelectronic industry. Other typical applications include high purity oxygen and hazardous gases. The products are capped and individually packed in double polyethylene bags to guarantee quality from delivery to point of use. *Read more on page 4.*

COLOR OF LABEL: 

---

## CQE

Tubes and Fittings with defined surface roughness for transport of High Purity Gases used in laboratories, calibration instruments and transport of pure oxygen and CFOS. Tubes and Fittings are produced, cleaned and packed in controlled processes to guarantee the same quality from delivery to point of use.

*Read more on page 20.*

COLOR OF LABEL: 

---

## CQ

Clean tubes produced for transport of High Purity Gases used in laboratories, calibration instruments and transport of pure oxygen and CFOS. Tubes are produced, cleaned and packed in controlled processes to guarantee the same quality from delivery to point of use.

*Read more on page 38.*

COLOR OF LABEL: 

---

## CQM

High Purity Tubes and Fittings with guaranteed hydrocarbon content  $< 2,5 \text{ mg/m}^2$  in accordance to HB 370 and ISO 7396-1, Part 1 for transport of medical gases in hospitals. Tubes and Fittings are cleaned and inspected in controlled processes to guarantee stable and high quality, focusing on patient safety in hospital environment. *Read more on page 42.*

COLOR OF LABEL: 

---

## COAXIAL

Tubes for safe transport of explosive, poisonous, corrosive and flammable gases. The coaxial tubing consists of an inner process tube and an outer safety tube. Both inner and outer tubes are prepared for orbital welding. *Read more on page 56.*

The information in this catalogue is intended to inform about Calamo products and availability. Depending on market needs, the content may be changed without notice.

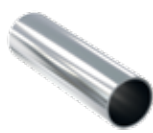

PAGE 5



PAGE 7



PAGE 9



PAGE 11



PAGE 13



PAGE 16

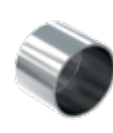

PAGE 19

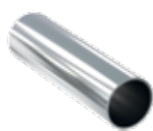

PAGE 21



PAGE 23



PAGE 25



PAGE 27



PAGE 29



PAGE 33

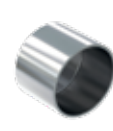

PAGE 36

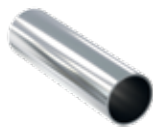

PAGE 39



PAGE 41

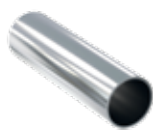

PAGE 43



PAGE 45



PAGE 47



PAGE 49



PAGE 51



PAGE 53



PAGE 55



PAGE 56

# PQE ELECTROPOLISHED TUBES AND FITTINGS

## *Stainless steel tube system* for Ultra Clean Gassystems

CALAMO PQE products are suitable for transport of Ultra High Purity Gas Systems in semiconductor and microchip manufacturing using corrosive or hazardous gases high purity oxygen. Tubes and Fittings are electropolished, clean room treated and individually packed to guarantee a high quality until the final installation.



### Products

Stainless steel tubes, tees, elbows, reducers and caps.

- Outside diameter: 6,00 – 152,40 mm
- Available as coaxial system

### Standard

Steel grade: EN 1.4404/1.4435/1.4432, ASTM 316L

Seamless: EN 10216-5 TC1, ASTM A269/A270, ASME SA213

Welded: EN 10217-7 TC1, ASTM A270/A269, ASME SA 249

Tolerances: ISO 1127 D4/T3, D3/T3, D2/T3, D2/T2, ASTM A269/A270

### Specification

- Raw material
  - Seamless and welded tubes and fittings
  - Bright annealed or annealed
- Electropolishing
  - Electropolished inside in accordance with SWID-4561
- Surface roughness
  - Ra inside 0,25µm (10µinch)
- Cleanroom treated in accordance with SWID-4561
  - Class ISO 4/5, FED 209 10/100
  - Rinsing with de-ionized water 18 MΩcm
  - Dried with hot nitrogen gas
  - End capped and protected in double polyethylene bags



### Certificate

CALAMO is certified in accordance with the following system (quality) ISO 9001 and (environment) ISO 14001.

### Manufacturing

- Raw material manufactured only from selected and approved suppliers according to CALAMO specifications.
- Electropolishing processes and technology are developed by CALAMO.
- Final cleaning with operation inside clean room using 70° C hot deionized water. Drying with high purity and heated nitrogen.
- Each sleeve is marked with a unique label that can be traced back to the certificate.
- A clean nylon film is placed over each end prior to ends are capped. Finally products are packed in double polyethylene bags.

### Advantages

CALAMO has a unique quality and service due to an integrated value chain.

- Receiving inspection and a large raw material stock to safeguard stable deliveries and short project lead time
- Electropolishing, cleaning, packing and inspection is conducted in the same facility creating stability in quality and short lead time.
- Daily deliveries from our stock of finished products.
- PQE products are end treated and ready for orbital welding.

# CALAMO - PQE - TUBE

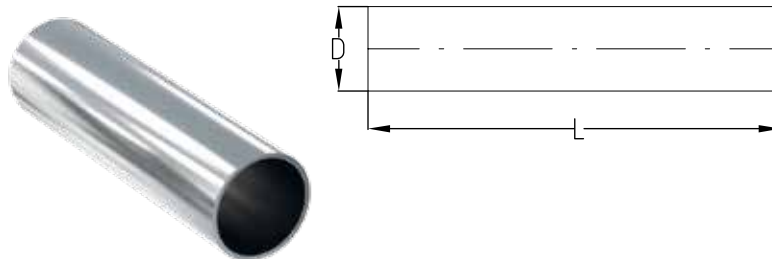

(L) Nominal length 6 000 mm for execution S

(L) Nominal length 6 100 mm for execution W

DN	(D) x wall (mm)	Weight (Kg/m)	Pressure <sup>1</sup> (Bar)	Article number	Product name	Execution <sup>2</sup> S/W	Stock <sup>3</sup> ○ / ●
8	6,35 x 0,89 mm 1/4 x 0.035"	0,123	331	0100118	PQE	S	●
10	9,53 x 0,89 mm 3/8 x 0.035"	0,195	210	0100278	PQE	S	●
15	12,70 x 1,24 mm 1/2 x 0.049"	0,353	221	0100558	PQE	S	●
20	19,05 x 1,65mm 3/4 x 0.065"	0,719	194	0100893	PQE	S	●
25	25,40 x 1,65mm 1 x 0.065"	0,974	182	0101170	PQE	S	●
40	38,1 x 1,65mm 1 1/2 x 0.065"	1,500	93	0131480	PQE	W	●
50	50,8 x 1,65mm 2 x 0.065"	2,030	69	0131680	PQE	W	●
65	63,5 x 1,65mm 2 1/2 x 0.065"	2,500	38	0131780	PQE	W	○
80	76,2 x 1,65mm 3 x 0.065"	3,056	46	0131820	PQE	W	●
100	101,60 x 2,11mm 4 x 0.083"	5,210	31	0132000	PQE	W	●
150	152,4 x 2,77mm 6 x 0.109"	10,287	27	-	PQE	W	○

<sup>1)</sup> Maximum operating pressure at maximum 20 C° according to EN 13480-3 <sup>2)</sup> Execution: S = Manufactured from seamless tubes W = Manufactured from welded tubes

<sup>3)</sup> ● = Stock standard product, ○ = Made to order

# CALAMO - PQE - TUBE

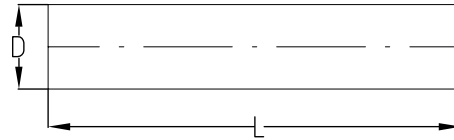

(L) Nominal length 6 000 mm

(D) x wall (mm)	Weight (Kg/m)	Pressure <sup>1</sup> (Bar)	Article number	Product name	Execution <sup>2</sup> S/W	Stock <sup>3</sup> ○ / ●
6,00 x 1,00 mm	0,124	462	0100040	PQE	S	●
8,00 x 1,00 mm	0,174	333	0100200	PQE	S	●
10,00 x 1,00 mm	0,223	261	0100360	PQE	S	●
12,00 x 1,00 mm	0,273	214	0100440	PQE	S	●
18,00 x 1,50 mm	0,615	234	0100810	PQE	S	●
28,00 x 1,50 mm	0,987	146	0101321	PQE	S	●

<sup>1)</sup> Maximum operating pressure at maximum 20 C° according to EN 13480-3 <sup>2)</sup> Execution: S = Manufactured from seamless tubes W = Manufactured from welded tubes  
<sup>3)</sup> ● = Stock standard product, ○ = Made to order

# CALAMO – PQE – ELBOW 90°

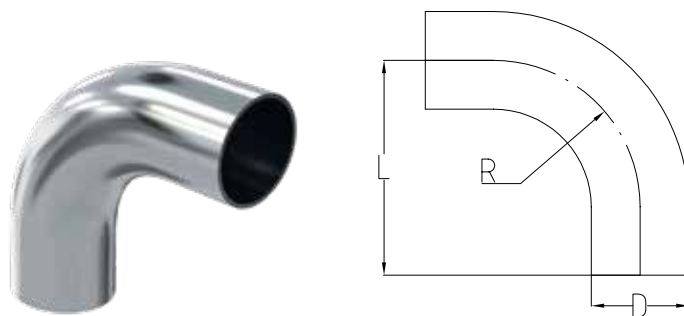

DN	(D) x wall (mm)	Weight (Kg/m)	Pressure <sup>1</sup> (Bar)	(L) Length (mm)	(R) Radius (mm)	Article number	Product name	Execution <sup>2</sup> S/W	Stock <sup>3</sup> ○ / ●
8	6,35 x 0,89 mm 1/4 x 0.035"	0,012	299	67	26	1110120	PQE	S	○
10	9,53 x 0,89 mm 3/8 x 0.035"	-	-	-	-	1110280US	PQE	S	○
15	12,70 x 1,24 mm 1/2 x 0.049"	0,044	200	76	29	1110560	PQE	S	●
20	19,05 x 1,65 mm 3/4 x 0.065"	0,087	153	76	29	1110880	PQE	S	○
25	25,40x1,65 mm 1 x 0.065"	0,182	113	76	38	1111160	PQE	S	○
40	38,1 x 1,65 mm 1 1/2 x 0.065"	0,249	44	95	57	1131480EUS	PQE	W	○
50	50,8 x 1,65 mm 2 x 0.065"	0,424	33	121	76	1131680EUS	PQE	W	○
65	63,5 x 1,65 mm 2 1/2 x 0.065"	0,596	31	140	95	1131780NL	PQE	W	○
80	76,2 x 1,65 mm 3 x 0.065"	0,820	25	159	114	1131820EUS	PQE	W	○
100	101,60 x 2,11 mm 4 x 0.083"	1,776	24	203	152	1132000EUS	PQE	W	○
150	152,4 x 2,77 mm 6 x 0.109"	4,998	20	292	229	1132055US	PQE	W	○

<sup>1)</sup> Maximum operating pressure at maximum 20 C° according to EN 13480-3 <sup>2)</sup> Execution: S = Manufactured from seamless tubes W = Manufactured from welded tubes  
<sup>3)</sup> ● = Stock standard product, ○ = Made to order

# CALAMO – PQE – ELBOW 90°

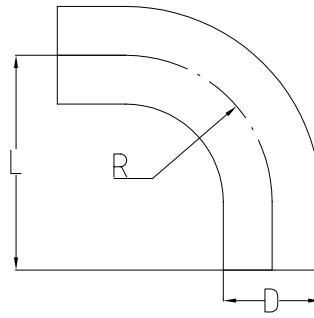

(D) x wall (mm)	Weight (Kg/m)	Pressure <sup>1</sup> (Bar)	(L) Length (mm)	(R) Radius (mm)	Article number	Product name	Execution <sup>2</sup> S/W	Stock <sup>3</sup> ○ / ●
6,00 x 1,00 mm	-	-	40	16	-	PQE	S	○
8,00 x 1,00 mm	-	-	25	24	-	PQE	S	○
10,00 x 1,00 mm	-	-	51	26	-	PQE	S	○
12,00 x 1,00 mm	-	-	51	26	1110440	PQE	S	○
18,00 x 1,50 mm	-	-	51	26	1110800	PQE	S	○
28,00 x 1,50 mm	0,156	87	90	50	1111320	PQE	S	○

<sup>1)</sup> Maximum operating pressure at maximum 20 C° according to EN 13480-3 <sup>2)</sup> Execution: S = Manufactured from seamless tubes W = Manufactured from welded tubes  
<sup>3)</sup> ● = Stock standard product, ○ = Made to order



# CALAMO - PQE - ELBOW 45°

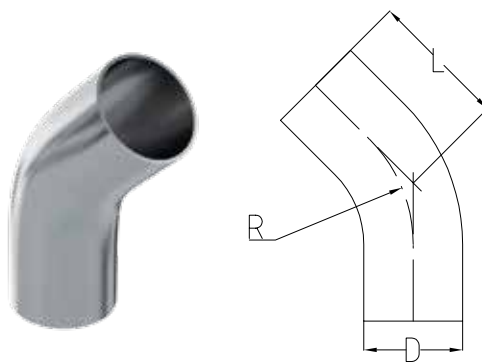

DN	(D) x wall (mm)	Weight (Kg/m)	Pressure <sup>1</sup> (Bar)	(L) Length (mm)	(R) Radius (mm)	Article number	Product name	Execution <sup>2</sup> S/W	Stock <sup>3</sup> ○ / ●
8	6,35 x 0,89 mm 1/4 x 0.035"	0,009	299	51	14	1110121US	PQE	S	○
10	9,53 x 0,89 mm 3/8 x 0.035"	0,020	204	51	29	1110281US	PQE	S	○
15	12,70 x 1,24 mm 1/2 x 0.049"	0,045	200	57	27	1110561US	PQE	S	●
20	19,05 x 1,65 mm 3/4 x 0.065"	0,092	153	57	29	1110881US	PQE	S	○
25	25,40x1,65 mm 1 x 0.065"	0,157	113	57	38	1111161	PQE	S	○
40	38,1 x 1,65 mm 1 1/2 x 0.065"	0,194	44	64	57	1131481RB	PQE	W	○
50	50,8 x 1,65 mm 2 x 0.065"	0,312	33	76	76	1131681RB	PQE	W	○
65	63,5 x 1,65 mm 2 1/2 x 0.065"	0,435	33	86	95	1131781NL	PQE	W	○
80	76,2 x 1,65 mm 3 x 0.065"	0,569	27	92	114	1131823NL	PQE	W	○
100	101,60 x 2,11 mm 4 x 0.083"	1,203	26	114	152	1132001NL	PQE	W	○
150	152,4 x 2,77 mm 6 x 0.109"	3,318	21	159	229	1332056NL	PQE	W	○

<sup>1)</sup> Maximum operating pressure at maximum 20 C° according to EN 13480-3 <sup>2)</sup> Execution: S = Manufactured from seamless tubes W = Manufactured from welded tubes  
<sup>3)</sup> ● = Stock standard product, ○ = Made to order

# CALAMO - PQE - ELBOW 45°

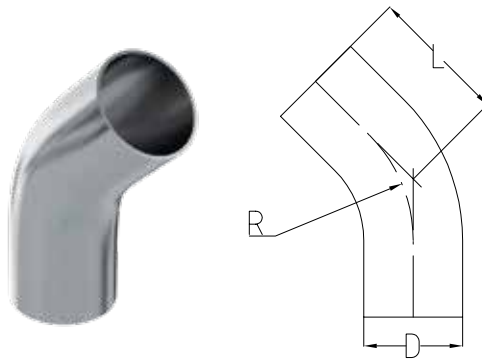

(D) x wall (mm)	Weight (Kg/m)	Pressure <sup>1</sup> (Bar)	(L) Length (mm)	(R) Radius (mm)	Article number	Product name	Execution <sup>2</sup> S/W	Stock <sup>3</sup> ○ / ●
6,00 x 1,00 mm	-	-	-	-	-	PQE	S	○
8,00 x 1,00 mm	-	-	-	-	-	PQE	S	○
10,00 x 1,00 mm	-	-	-	-	-	PQE	S	○
12,00 x 1,00 mm	0,019	175	36	26	-	PQE	S	○
18,00 x 1,50 mm	0,043	140	36	26	1110801	PQE	S	○
28,00 x 1,50 mm	0,118	87	50	50	-	PQE	S	○

<sup>1)</sup> Maximum operating pressure at maximum 20 C° according to EN 13480-3 <sup>2)</sup> Execution: S = Manufactured from seamless tubes W = Manufactured from welded tubes  
<sup>3)</sup> ● = Stock standard product, ○ = Made to order

# CALAMO – PQE – EQUAL TEE

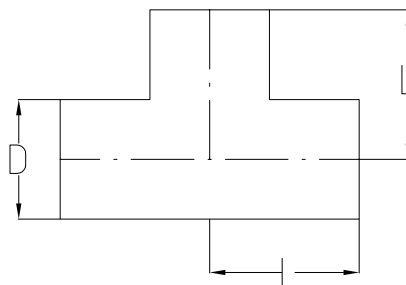

DN	(D) x wall (mm)	Weight (Kg/m)	Pressure <sup>1</sup> (Bar)	(L) Length (mm)	Article number	Product name	Execution <sup>2</sup> S/W	Stock <sup>3</sup> ○ / ●
8	6,35 x 0,89 mm 1/4 x 0.035"	0,011	215	45	1104120NL	PQE	S	●
10	9,53 x 0,89 mm 3/8 x 0.035"	0,025	123	45	1104280NL	PQE	S	●
15	12,70 x 1,24 mm 1/2 x 0.049"	0,055	131	48	1104560NLH	PQE	S	●
20	19,05 x 1,65 mm 3/4 x 0.065"	0,110	111	51	1104880NL	PQE	S	○
25	25,40x1,65 mm 1 x 0.065"	0,175	75	54	1105160NL	PQE	S	●
40	38,1 x 1,65 mm 1 1/2 x 0.065"	-	-	-	-	PQE	W	○
50	50,8 x 1,65 mm 2 x 0.065"	0,454	30	73	1135680	PQE	W	○
65	63,5 x 1,65 mm 2 1/2 x 0.065"	0,588	22	79	1135780NL	PQE	W	○
80	76,2 x 1,65 mm 3 x 0.065"	0,755	17	86	1135820NL	PQE	W	○
100	101,60 x 2,11 mm 4 x 0.083"	1,423	16	105	1136000NL	PQE	W	○
150	152,4 x 2,77 mm 6 x 0.109"	3,907	14	143	1136025	PQE	W	○

<sup>1)</sup> Maximum operating pressure at maximum 20 C° according to EN 13480-3 <sup>2)</sup> Execution: S = Manufactured from seamless tubes W = Manufactured from welded tubes  
<sup>3)</sup> ● = Stock standard product, ○ = Made to order

# CALAMO – PQE – EQUAL TEE

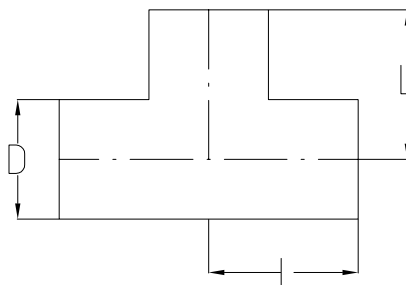

(D) x wall (mm)	Weight (Kg/m)	Pressure <sup>1</sup> (Bar)	(L) Length (mm)	Article number	Product name	Execution <sup>2</sup> S/W	Stock <sup>3</sup> ○ / ●
6,00 x 1,00 mm	0,013	304	30	1104040	PQE	S	●
8,00 x 1,00 mm	0,027	204	30	1104200	PQE	S	●
10,00 x 1,00 mm	0,036	151	30	0100360	PQE	S	○
12,00 x 1,00 mm	0,044	118	35	1104440	PQE	S	●
18,00 x 1,50 mm	0,103	131	35	1104800	PQE	S	●
28,00 x 1,50 mm	0,176	72	50	1105320	PQE	W	○

<sup>1)</sup> Maximum operating pressure at maximum 20 C° according to EN 13480-3 <sup>2)</sup> Execution: S = Manufactured from seamless tubes W = Manufactured from welded tubes  
<sup>3)</sup> ● = Stock standard product, ○ = Made to order

# CALAMO – PQE – UNEQUAL TEE

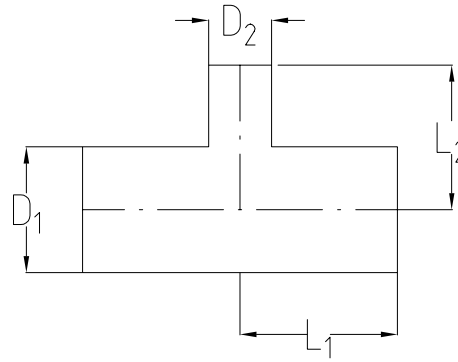

DN	(D1) x wall (mm)	(D2) x wall (mm)	Weight (Kg/m)	Pressure <sup>1</sup> (Bar)	(L1) Length (mm)	(L2) Length (mm)	Article number	Product name	Execution <sup>2</sup> S/W	Stock <sup>3</sup> ○ / ●
10/8	9,53 x 0,89 mm 3/8 x 0.035"	6,35 x 0,89 mm 1/4 x 0.035"	0,222	158	45	45	1104286NL	PQE	S	○
15/8	12,70 x 1,24 mm 1/2 x 0.049"	6,35 x 0,89 mm 1/4 x 0.035"	0,044	163	48	48	1104566NL	PQE	S	○
15/10	12,70 x 1,24 mm 1/2 x 0.049"	9,53 x 0,89 mm 3/8 x 0.035"	0,047	130	48	48	1104568	PQE	S	○
20/8	19,05 x 1,65 mm 3/4 x 0.065"	6,35 x 0,89 mm 1/4 x 0.035"	0,083	149	51	51	1104886	PQE	S	○
20/10	19,05 x 1,65 mm 3/4 x 0.065"	9,53 x 0,89 mm 3/8 x 0.035"	0,086	123	51	51	1104888	PQE	S	○
20/15	19,05 x 1,65 mm 3/4 x 0.065"	12,70 x 1,24 mm 1/2 x 0.049"	0,093	121	51	51	1104890	PQE	S	○
25/8	25,40 x 1,65 mm 1 x 0.065"	6,35 x 0,89mm 1/4 x 0.035"	0,131	115	54	54	1105166	PQE	S	○
25/10	25,40 x 1,65 mm 1 x 0.065"	9,53 x 0,89 mm 3/8 x 0.035"	0,131	98	54	54	1105167	PQE	S	○
25/15	25,40 x 1,65 mm 1 x 0.065"	12,70 x 1,24 mm 1/2 x 0.049"	0,135	97	54	54	1105168	PQE	S	○
25/20	25,40 x 1,65 mm 1 x 0.065"	19,05 x 1,65 mm 3/4 x 0.065"	0,256	91	54	54	1105175	PQE	S	○
40/15	38,1 x 1,65 mm 1 1/2 x 0.065"	12,70 x 1,24 mm 1/2 x 0.049"	-	-	60	60	1105490	PQE	W	○
40/20	38,1 x 1,65 mm 1 1/2 x 0.065"	19,05 x 1,65 mm 3/4 x 0.065"	-	-	60	60	1105498	PQE	W	○
40/25	38,1 x 1,65 mm 1 1/2 x 0.065"	25,40 x 1,65 mm 1 x 0.065"	-	-	60	60	1105501	PQE	W	○
50/15	50,8 x 1,65 mm 2 x 0.065"	12,70 x 1,24 mm 1/2 x 0.049"	-	-	67	67	1105690US	PQE	W-S	○
50/20	50,8 x 1,65 mm 2 x 0.065"	19,05 x 1,65 mm 3/4 x 0.065"	-	-	67	67	-	PQE	W-S	○
50/25	50,8 x 1,65 mm 2 x 0.065"	25,40 x 1,65 mm 1 x 0.065"	-	-	67	67	1105701NL	PQE	W-S	○
50/40	50,8 x 1,65 mm 2 x 0.065"	38,1 x 1,65 mm 1 1/2 x 0.065"	-	-	67	67	1105704NL	PQE	W	○

<sup>1)</sup> Maximum operating pressure at maximum 20 C° according to EN 13480-3 <sup>2)</sup> Execution: S = Manufactured from seamless tubes W = Manufactured from welded tubes  
<sup>3)</sup> ● = Stock standard product, ○ = Made to order

# CALAMO – PQE – UNEQUAL TEE

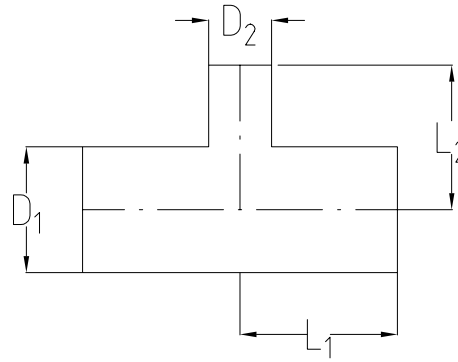

DN	(D1) x wall (mm)	(D2) x wall (mm)	Weight (Kg/m)	Pressure <sup>1</sup> (Bar)	(L1) Length (mm)	(L2) Length (mm)	Article number	Product name	Execution <sup>2</sup> S/W	Stock <sup>3</sup> ○ / ●
65/15	63,5 x 1,65 mm 2 1/2 x 0.065"	12,70 x 1,24 mm 1/2 x 0.049"	-	-	73	73	-	PQE	W	○
65/20	63,5 x 1,65 mm 2 1/2 x 0.065"	19,05 x 1,65 mm 3/4 x 0.065"	-	-	73	73	-	PQE	W	○
65/25	63,5 x 1,65 mm 2 1/2 x 0.065"	25,40 x 1,65 mm 1 x 0.065"	0,501	38	73	73	1135785NL	PQE	W	○
65/40	63,5 x 1,65 mm 2 1/2 x 0.065"	38,1 x 1,65 mm 1 1/2 x 0.065"	-	-	73	73	-	PQE	W	○
65/50	63,5 x 1,65 mm 2 1/2 x 0.065"	50,8 x 1,65 mm 2 x 0.065"	-	-	73	73	-	PQE	W	○
80/15	76,2 x 1,65 mm 3 x 0.065"	12,70 x 1,24 mm 1/2 x 0.049"	0,601	32	79	79	1135823	PQE	W	○
80/20	76,2 x 1,65 mm 3 x 0.065"	19,05 x 1,65 mm 3/4 x 0.065"	-	-	79	79	-	PQE	W	○
80/25	76,2 x 1,65 mm 3 x 0.065"	25,40 x 1,65 mm 1 x 0.065"	0,636	32	79	79	1135825	PQE	W	○
80/40	76,2 x 1,65 mm 3 x 0.065"	38,1 x 1,65 mm 1 1/2 x 0.065"	0,666	26	79	79	1135826	PQE	W	○
80/50	76,2 x 1,65 mm 3 x 0.065"	50,8 x 1,65 mm 2 x 0.065"	0,696	22	79	79	1135827NL	PQE	W	○
80/65	76,2 x 1,65 mm 3 x 0.065"	63,5 x 1,65 mm 2 1/2 x 0.065"	-	-	79	79	-	PQE	W	○
100/25	101,60 x 2,11 mm 4 x 0.083"	25,40 x 1,65 mm 1 x 0.065"	1,181	31	92	92	1136010	PQE	W	○
100/40	101,60 x 2,11 mm 4 x 0.083"	38,1 x 1,65 mm 1 1/2 x 0.065"	1,211	26	92	92	1136012	PQE	W	○
100/50	101,60 x 2,11 mm 4 x 0.083"	50,8 x 1,65 mm 2 x 0.065"	1,241	22	98	98	1136018	PQE	W	○
100/65	101,60 x 2,11 mm 4 x 0.083"	63,5 x 1,65 mm 2 1/2 x 0.065"	-	-	98	98	-	PQE	W	○
100/80	101,60 x 2,11 mm 4 x 0.083"	76,2 x 1,65 mm 3 x 0.065"	1,300	17	98	98	1136022	PQE	W	○
150/50	152,4 x 2,77 mm 6 x 0.109"	50,8 x 1,65 mm 2 x 0.065"	-	-	130	130	-	PQE	W	○
150/80	152,4 x 2,77 mm 6 x 0.109"	76,2 x 1,65 mm 3 x 0.065"	-	-	130	130	-	PQE	W	○
150/100	152,4 x 2,77 mm 6 x 0.109"	101,60 x 2,11 mm 4 x 0.083"	3,522	14	130	130	1136050US	PQE	W	○

<sup>1)</sup> Maximum operating pressure at maximum 20 C° according to EN 13480-3 <sup>2)</sup> Execution: S = Manufactured from seamless tubes W = Manufactured from welded tubes  
<sup>3)</sup> ● = Stock standard product, ○ = Made to order

# CALAMO – PQE – UNEQUAL TEE

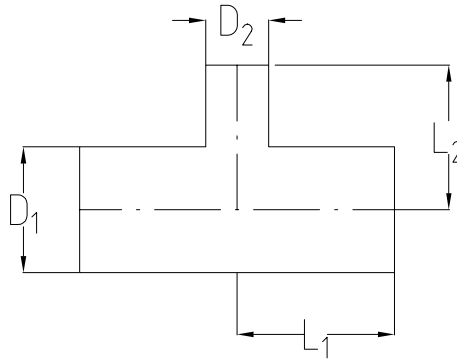

(D1) x wall (mm)	(D2) x wall (mm)	Weight (Kg/m)	Pressure <sup>1</sup> (Bar)	(L1) Length (mm)	(L2) Length (mm)	Article number	Product name	Execution <sup>2</sup> S/W	Stock <sup>3</sup> ○ / ●
8,00 x 1,00 mm	6,00 x 1,00 mm	0,025	245	30	30	1104201	PQE	S	○
10,00 x 1,00 mm	6,00 x 1,00 mm	0,031	205	30	30	1104366	PQE	S	○
10,00 x 1,00 mm	8,00 x 1,00 mm	0,033	174	30	30	1304363	PQE	S	○
12,00 x 1,00 mm	6,00 x 1,00 mm	0,037	176	35	35	1104446	PQE	S	●
12,00 x 1,00 mm	8,00 x 1,00 mm	0,039	151	35	35	1104447	PQE	S	○
12,00 x 1,00 mm	10,00 x 1,00 mm	0,042	133	35	35	1104448	PQE	S	○
18,00 x 1,50 mm	6,00 x 1,00 mm	0,079	185	35	35	1104806	PQE	S	●
18,00 x 1,50 mm	8,00 x 1,00 mm	0,081	163	35	35	1104807	PQE	S	○
18,00 x 1,50 mm	10,00 x 1,00 mm	0,084	145	35	35	1104808	PQE	S	○
18,00 x 1,50 mm	12,00x1,00 mm	0,086	130	35	35	1104809	PQE	S	●
28,00 x 1,50 mm	12,00 x 1,00 mm	0,140	93	50	50	1105329	PQE	S	○
28,00 x 1,50 mm	18,00 x 1,50 mm	0,157	95	50	50	1105332	PQE	S	○

<sup>1)</sup> Maximum operating pressure at maximum 20 C° according to EN 13480-3 <sup>2)</sup> Execution: S = Manufactured from seamless tubes W = Manufactured from welded tubes  
<sup>3)</sup> ● = Stock standard product, ○ = Made to order

# CALAMO – PQE – CONCENTRIC REDUCER

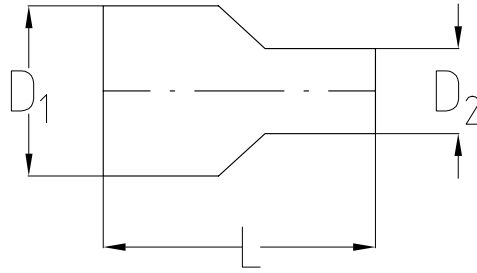

DN	(D1) x wall (mm)	(D2) x wall (mm)	Weight (Kg/m)	Pressure <sup>1</sup> (Bar)	(L1) Length (mm)	Article number	Product name	Execution <sup>2</sup> B/P	Stock <sup>3</sup> ○ / ●
10/8	9,53 x 0,89 mm 3/8 x 0.035"	6,35 x 0,89 mm 1/4 x 0.035"	0,050	-	41	1107280	PQE	B	○
15/8	12,70 x 1,24 mm 1/2 x 0.049"	6,35 x 0,89 mm 1/4 x 0.035"	0,050	-	38	1107560	PQE	B	○
15/10	12,70 x 1,24 mm 1/2 x 0.049"	9,53 x 0,89 mm 3/8 x 0.035"	0,050	-	38	1107562	PQE	B	○
20/8	19,05 x 1,65 mm 3/4 x 0.065"	6,35 x 0,89 mm 1/4 x 0.035"	0,075	-	-	1107881	PQE	B	○
20/10	19,05 x 1,65 mm 3/4 x 0.065"	9,53 x 0,89 mm 3/8 x 0.035"	0,075	-	51	1107893	PQE	B	○
20/15	19,05 x 1,65 mm 3/4 x 0.065"	12,70 x 1,24 mm 1/2 x 0.049"	0,075	-	60	1107883	PQE	B	○
25/15	25,40 x 1,65 mm 1 x 0.065"	12,70 x 1,24 mm 1/2 x 0.049"	0,100	-	60	1108163	PQE	B	○
25/20	25,40 x 1,65 mm 1 x 0.065"	19,05 x 1,65 mm 3/4 x 0.065"	0,100	-	-	1108168	PQE	B	○
40/15	38,1 x 1,65 mm 1 1/2 x 0.065"	12,70 x 1,24 mm 1/2 x 0.049"	0,125	-	80	1108482	PQE	B	○
40/20	38,1 x 1,65 mm 1 1/2 x 0.065"	19,05 x 1,65 mm 3/4 x 0.065"	0,125	-	76	1108485	PQE	B	○
40/25	38,1 x 1,65 mm 1 1/2 x 0.065"	25,40 x 1,65 mm 1 x 0.065"	0,125	-	64	1108487	PQE	B	○
50/25	50,8 x 1,65 mm 2 x 0.065"	25,40 x 1,65 mm 1 x 0.065"	0,300	-	86	1108688	PQE	B	○
50/40	50,8 x 1,65 mm 2 x 0.065"	38,1 x 1,65 mm 1 1/2 x 0.065"	0,300	-	64	1108690	PQE	B	○

<sup>1)</sup> Maximum operating pressure at maximum 20 C° according to EN 13480-3 <sup>2)</sup> B = Manufactured from solid bar, P = Pressed plate  
<sup>3)</sup> ● = Stock standard product, ○ = Made to order



# CALAMO – PQE – CONCENTRIC REDUCER

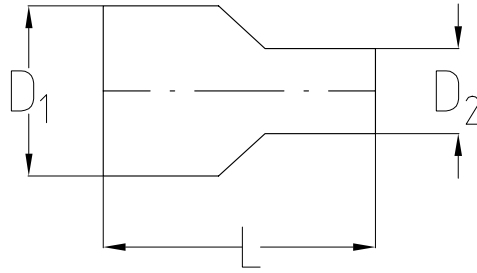

DN	(D1) x wall (mm)	(D2) x wall (mm)	Weight (Kg/m)	Pressure <sup>1</sup> (Bar)	(L1) Length (mm)	Article number	Product name	Execution <sup>2</sup> B/P	Stock <sup>3</sup> ○ / ●
65/25	63,5 x 1,65 mm 2 1/2 x 0.065"	25,40 x 1,65 mm 1 x 0.065"	0,500	-	100	1108812	PQE	B	○
65/40	63,5 x 1,65 mm 2 1/2 x 0.065"	38,1 x 1,65 mm 1 1/2 x 0.065"	-	-	86	-	PQE	B	○
65/50	63,5 x 1,65 mm 2 1/2 x 0.065"	50,8 x 1,65 mm 2 x 0.065"	0,500	-	64	1108816	PQE	B	○
80/40	76,2 x 1,65 mm 3 x 0.065"	38,1 x 1,65 mm 1 1/2 x 0.065"	0,750	-	108	1108826	PQE	B	○
80/50	76,2 x 1,65 mm 3 x 0.065"	50,8 x 1,65 mm 2 x 0.065"	0,750	-	86	1108832	PQE	B	○
80/65	76,2 x 1,65 mm 3 x 0.065"	63,5 x 1,65 mm 2 1/2 x 0.065"	0,750	-	67	1108836	PQE	B	○
100/50	101,60 x 2,11 mm 4 x 0.083"	50,8 x 1,65 mm 2 x 0.065"	0,890	-	130	1109013	PQE	B	○
100/65	101,60 x 2,11 mm 4 x 0.083"	63,5 x 1,65 mm 2 1/2 x 0.065"	-	-	108	-	PQE	B	○
100/80	101,60 x 2,11 mm 4 x 0.083"	76,2 x 1,65 mm 3 x 0.065"	0,890	-	98	1109033	PQE	B	○
150/80	152,4 x 2,77 mm 6 x 0.109"	76,2 x 1,65 mm 3 x 0.065"	-	-	185	-	PQE	B	○
150/100	152,4 x 2,77 mm 6 x 0.109"	101,60 x 2,11 mm 4 x 0.083"	1,200	-	143	1109050	PQE	B	○

<sup>1)</sup> Maximum operating pressure at maximum 20 C° according to EN 13480-3 <sup>2)</sup> B = Manufactured from solid bar, P = Pressed plat  
<sup>3)</sup> ● = Stock standard product, ○ = Made to order

# CALAMO – PQE – CONCENTRIC REDUCER

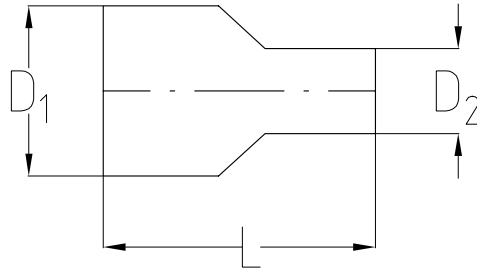

(D1) x wall (mm)	(D2) x wall (mm)	Weight (Kg/m)	Pressure <sup>1</sup> (Bar)	(L1) Length (mm)	Article number	Product name	Execution <sup>2</sup> B/P	Stock <sup>3</sup> ○ / ●
8,00 x 1,00 mm	6,00 x 1,00 mm	-	-	38	1107210	PQE	B	○
10,00 x 1,00 mm	6,00 x 1,00 mm	-	-	38	-	PQE	B	○
10,00 x 1,00 mm	8,00 x 1,00 mm	-	-	38	-	PQE	B	○
12,00 x 1,00 mm	6,00 x 1,00 mm	0,050	176	38	1107442	PQE	B	○
12,00 x 1,00 mm	8,00 x 1,00 mm	0,050	-	38	1107450	PQE	B	○
12,00 x 1,00 mm	10,00 x 1,00 mm	0,050	-	38	1107452	PQE	B	○
18,00 x 1,50 mm	10,00 x 1,00 mm	-	-	38	-	PQE	B	○
18,00 x 1,50 mm	12,00x1,00 mm	0,100	119	38	1107806	PQE	B	○
28,00 x 1,50 mm	18,00 x 1,50 mm	0,100	-	70	1108325	PQE	B	○

<sup>1)</sup> Maximum operating pressure at maximum 20 C° according to EN 13480-3 <sup>2)</sup> B = Manufactured from solid bar, P = Pressed plat

<sup>3)</sup> ● = Stock standard product, ○ = Made to order

# CALAMO – PQE – END CAP

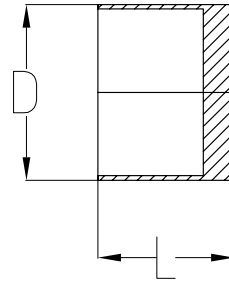

DN	(D) x wall (mm)	Weight (Kg/m)	Pressure <sup>1</sup> (Bar)	(L1) Length (mm)	Article number	Product name	Execution <sup>2</sup> B/P	Stock <sup>3</sup> ○ / ●
8	6,35 x 0,89 mm 1/4 x 0.035"	0,050	-	-	1109121	PQE	B	○
10	9,53 x 0,89 mm 3/8 x 0.035"	0,050	-	-	1109280	PQE	B	○
15	12,70 x 1,24 mm 1/2 x 0.049"	0,050	-	-	1109566	PQE	B	○
20	19,05 x 1,65 mm 3/4 x 0.065"	0,150	-	-	1109609	PQE	B	○
25	25,40 x 1,65 mm 1 x 0.065"	0,150	-	-	1109640	PQE	B	○
40	38,1 x 1,65 mm 1 1/2 x 0.065"	0,400	-	-	1109721	PQE	B	○
50	50,8 x 1,65 mm 2 x 0.065"	0,400	-	-	1109761	PQE	B	○
65	63,5 x 1,65mm 2 1/2 x 0.065"	1,000	-	-	1109780	PQE	B	○
80	76,2 x 1,65mm 3 x 0.065"	1,500	-	-	1109800	PQE	B	○
100	101,60 x 2,11 mm 4 x 0.083"	2,500	-	-	1109900	PQE	B	○
150	152,4 x 2,77 mm 6 x 0.109"	5,500	-	-	-	PQE	B	- <sup>4</sup>

(D) x wall (mm)	Weight (Kg/m)	Pressure <sup>1</sup> (Bar)	(L1) Length (mm)	Article number	Product name	Execution <sup>2</sup> B/P	Stock <sup>3</sup> ○ / ●
6,00 x 1,00 mm	-	-	-	-	PQE	B	- <sup>4</sup>
8,00 x 1,00 mm	-	-	-	-	PQE	B	- <sup>4</sup>
10,00 x 1,00 mm	-	-	-	-	PQE	B	- <sup>4</sup>
12,00 x 1,00 mm	-	37	-	-	PQE	B	○
18,00 x 1,50 mm	-	45	-	-	PQE	B	○
28,00 x 1,50 mm	-	45	-	-	PQE	B	○

<sup>1)</sup> Maximum operating pressure at maximum 20 C° according to EN 13480-3 <sup>2)</sup> B = Manufactured from solid bar, P = Pressed plat

<sup>3)</sup> ● = Stock standard product, ○ = Made to order <sup>4)</sup> Special request

# CQE CLEAN TUBES AND FITTINGS

## *Stainless steel tube system* for High Purity Gas Systems

CALAMO CQE is manufactured for transporting high purity gases for laboratories, calibration gases or transport of oxygen. The manufacturing process is controlled to guarantee a stable quality from gas source to point of use.



### Products

Stainless steel tubes, tees, elbows and reducers.

- Outside diameter: 6,00 – 152,40 mm

### Standard

Steel grade: EN 1.4404/1.4435/1.4432, ASTM 316L

Seamless: EN 10216-5 TC1, ASTM A269/A270, ASME SA213

Welded: EN 10217-7 TC1, ASTM A270/A269, ASME SA 249

Tolerances: ISO 1127 D4/T3, D3/T3, D2/T3, D2/T2, ASTM A269/A270

### Specification

- Raw material
  - Seamless and welded tubes and fittings
  - Bright annealed or annealed
- Manufactured in accordance with SWID-4545
- Inside surface roughness Ra 0,4 - 0,6 µm
- In accordance with ASTM G93
- For deliveries within Sweden and Norway metric tubing outer diameter 6,00 - 35,00 mm will be delivered with hydrocarbon content <2,5mg/m<sup>2</sup>. Available on request for other regions and dimensions.



### Certificate

CALAMO is certified in accordance with following systems (quality) ISO 9001 and (environment) ISO 14001.

### Manufacturing

- Cleanliness achieved through advanced surface treatment and packing technique.
- Final rinsing using deionized water.
- Tubes are dried with nitrogen from cryo tank.
- Individual surface control of cleanliness and surfaces.
- CQE-products are sealed with polyethylene caps and individually packed in polyethylene sleeves.

### Advantages

- Products are cleaned to transport high purity gases without interference with the process.
- Products are protected from contamination.
- Products have full traceability from steel customer to melt. Material certificate according to EN 10204 3.1.
- Each polyethylene sleeve is marked with a unique label that can be traced back to the certificate.
- The products, excluding Tees, fulfill the requirements according to PED 2014/68/EU. Tees on request.
- The products fulfill AFS 2016:1.
- A large stock of finished tubes and fittings safeguard short lead times and quick installations.
- CQE is prepared for orbital welding.
- CQE tubes with OD below 6-18 mm can be bent on-site with same cleanliness and durability.
- A large stock of finished tubes and fittings guarantee high service and short lead times.

# CALAMO - CQE - TUBE

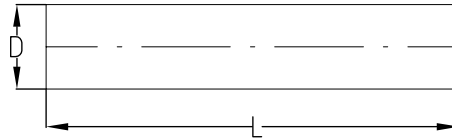

(L) Nominal length 6 000 mm for execution S

(L) Nominal length 6 100 mm for execution W

DN	(D) x wall (mm)	Weight (Kg/m)	Pressure <sup>1</sup> (Bar)	Article number	Product name	Execution <sup>2</sup> S/W	Stock <sup>3</sup> ○ / ●
8	6,35 x 0,89 mm 1/4 x 0.035"	0,123	331	0300112	CQE	S	●
10	9,53 x 0,89 mm 3/8 x 0.035"	0,195	210	0300280	CQE	S	●
15	12,70 x 1,24 mm 1/2 x 0.049"	0,353	221	0300560	CQE	S	●
20	19,05 x 1,65mm 3/4 x 0.065"	0,719	194	0300880	CQE	S	●
25	25,40 x 1,65mm 1 x 0.065"	0,974	182	0301160	CQE	S	●
40	38,1 x 1,65mm 1 1/2 x 0.065"	1,500	93	0331480	CQE	W	○
50	50,8 x 1,65mm 2 x 0.065"	2,030	69	0331680	CQE	W	○
65	63,5 x 1,65mm 2 1/2 x 0.065"	2,555	38	-	CQE	W	○
80	76,2 x 1,65mm 3 x 0.065"	3,056	46	0331820	CQE	W	○
100	101,60 x 2,11mm 4 x 0.083"	5,210	31	-	CQE	W	○
150	152,4 x 2,77mm 6 x 0.109"	10,378	27	-	CQE	W	○

<sup>1)</sup> Maximum operating pressure at maximum 20 C° according to EN 13480-3 <sup>2)</sup> Execution: S = Manufactured from seamless tubes W = Manufactured from welded tubes

<sup>3)</sup> ● = Stock standard product, ○ = Made to order

# CALAMO - CQE - TUBE

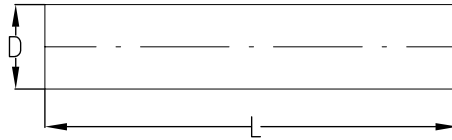

(L) Nominal length 6 000 mm

(D) x wall (mm)	Weight (Kg/m)	Pressure <sup>1</sup> (Bar)	Article number	Product name	Execution <sup>2</sup> S/W	Stock <sup>3</sup> ○ / ●
6,00 x 1,00 mm	0,124	462	0300040SW	CQE	S	●
8,00 x 1,00 mm	0,174	333	0300200SW	CQE	S	●
10,00 x 1,00 mm	0,223	261	0300360SW	CQE	S	●
12,00 x 1,00 mm	0,273	214	0300440SW	CQE	S	●
15,00 x 1,00 mm	0,350	125	0300700SW	CQE	S	●
18,00 x 1,50 mm	0,615	234	0300810	CQE	S	●
22,00 x 1,50 mm	0,769	157	0300970SW	CQE	S	●
28,00 x 1,50 mm	0,987	146	0301321	CQE	S	●
35,00 x 1,50 mm	1,260	116	0331450	CQE	W	○

<sup>1)</sup> Maximum operating pressure at maximum 20 C° according to EN 13480-3 <sup>2)</sup> Execution: S = Manufactured from seamless tubes W = Manufactured from welded tubes

<sup>3)</sup> ● = Stock standard product, ○ = Made to order

# CALAMO – CQE – ELBOW 90°

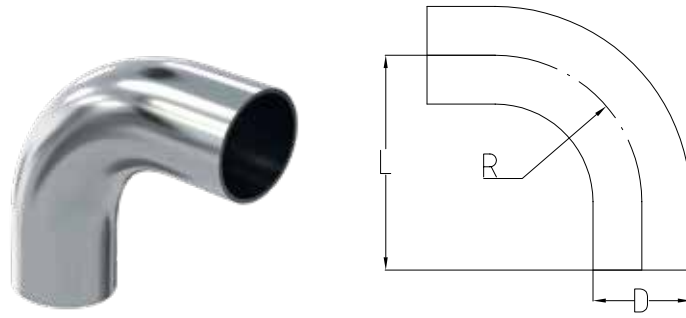

DN	(D) x wall (mm)	Weight (Kg/m)	Pressure <sup>1</sup> (Bar)	(L) Length (mm)	(R) Radius (mm)	Article number	Product name	Execution <sup>2</sup> S/W	Stock <sup>3</sup> ○ / ●
8	6,35 x 0,89 mm 1/4 x 0.035"	0,012	299	67	14	1310120US	CQE	S	○
10	9,53 x 0,89 mm 3/8 x 0.035"	0,025	204	67	29	1310280	CQE	S	○
15	12,70 x 1,24 mm 1/2 x 0.049"	0,044	200	76	27	1310560	CQE	S	○
20	19,05 x 1,65 mm 3/4 x 0.065"	0,087	153	76	29	1310880	CQE	S	○
25	25,40x1,65 mm 1 x 0.065"	0,182	113	76	38	1311160	CQE	S	○
40	38,1 x 1,65 mm 1 1/2 x 0.065"	0,249	44	95	57	1331480RB	CQE	W	●
50	50,8 x 1,65 mm 2 x 0.065"	0,424	33	121	76	1331680RB	CQE	W	○
65	63,5 x 1,65 mm 2 1/2 x 0.065"	0,596	31	140	95	1331780NL	CQE	W	○
80	76,2 x 1,65 mm 3 x 0.065"	0,820	25	159	114	1331820NL	CQE	W	○
100	101,60 x 2,11 mm 4 x 0.083"	1,776	24	203	152	1332000NL	CQE	W	○
150	152,4 x 2,77 mm 6 x 0.109"	4,998	20	292	229	1332055NL	CQE	W	○

<sup>1)</sup> Maximum operating pressure at maximum 20 C° according to EN 13480-3 <sup>2)</sup> Execution: S = Manufactured from seamless tubes W = Manufactured from welded tubes  
<sup>3)</sup> ● = Stock standard product, ○ = Made to order

# CALAMO – CQE – ELBOW 90°

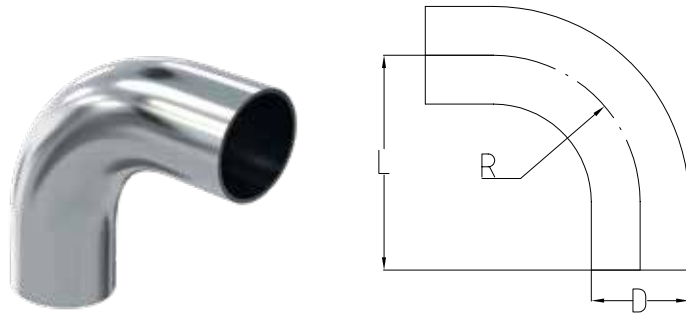

(D) x wall (mm)	Weight (Kg/m)	Pressure <sup>1</sup> (Bar)	(L) Length (mm)	(R) Radius (mm)	Article number	Product name	Execution <sup>2</sup> S/W	Stock <sup>3</sup> ○ / ●
6,00 x 1,00 mm	-	-	-	-	-	CQE	S	- <sup>4</sup>
8,00 x 1,00 mm	-	-	-	-	-	CQE	S	- <sup>4</sup>
10,00 x 1,00 mm	-	-	-	-	-	CQE	S	- <sup>4</sup>
12,00 x 1,00 mm	0,025	175	51	26	1310440	CQE	S	○
15,00 x 1,00 mm	-	-	-	-	-	CQE	S	- <sup>4</sup>
18,00 x 1,50 mm	0,056	140	51	26	1310800	CQE	S	●
28,00 x 1,50 mm	0,156	87	90	50	1311320	CQE	S	●
35,00 x 1,50 mm	-	-	95	55	1331440RB	CQE	W	●

<sup>1)</sup> Maximum operating pressure at maximum 20 C° according to EN 13480-3 <sup>2)</sup> Execution: S = Manufactured from seamless tubes W = Manufactured from welded tubes  
<sup>3)</sup> ● = Stock standard product, ○ = Made to order <sup>4)</sup> Special request



# CALAMO - CQE - ELBOW 45°

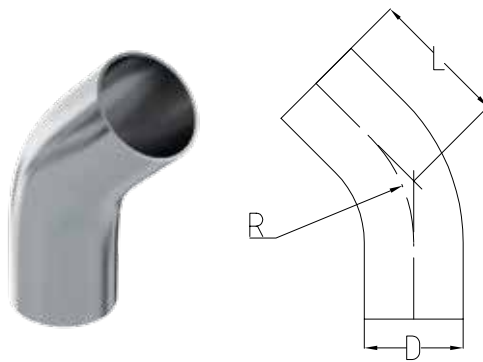

DN	(D) x wall (mm)	Weight (Kg/m)	Pressure <sup>1</sup> (Bar)	(L) Length (mm)	(R) Radius (mm)	Article number	Product name	Execution <sup>2</sup> S/W	Stock <sup>3</sup> ○ / ●
8	6,35 x 0,89 mm 1/4 x 0.035"	0,009	299	51	14	1310121US	CQE	S	○
10	9,53 x 0,89 mm 3/8 x 0.035"	-	-	-	-	1310281US	CQE	S	○
15	12,70 x 1,24 mm 1/2 x 0.049"	0,045	200	57	27	1310561	CQE	S	○
20	19,05 x 1,65 mm 3/4 x 0.065"	0,092	153	57	29	1310881	CQE	S	○
25	25,40x1,65 mm 1 x 0.065"	0,157	113	57	38	1311161	CQE	S	○
40	38,1 x 1,65 mm 1 1/2 x 0.065"	0,194	44	64	57	1331481RB	CQE	W	○
50	50,8 x 1,65 mm 2 x 0.065"	0,312	33	76	76	1331681RB	CQE	W	○
65	63,5 x 1,65 mm 2 1/2 x 0.065"	0,435	33	95	95	1331781NL	CQE	W	○
80	76,2 x 1,65 mm 3 x 0.065"	0,569	27	114	114	1331822NL	CQE	W	○
100	101,60 x 2,11 mm 4 x 0.083"	1,203	26	152	152	1332002NL	CQE	W	○
150	152,4 x 2,77 mm 6 x 0.109"	3,318	21	229	229	1332056NL	CQE	W	○

<sup>1)</sup> Maximum operating pressure at maximum 20 C° according to EN 13480-3 <sup>2)</sup> Execution: S = Manufactured from seamless tubes W = Manufactured from welded tubes  
<sup>3)</sup> ● = Stock standard product, ○ = Made to order

# CALAMO - CQE - ELBOW 45°

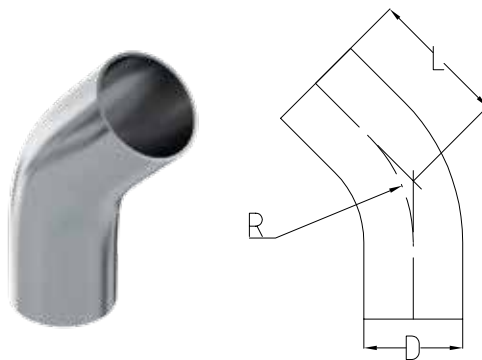

(D) x wall (mm)	Weight (Kg/m)	Pressure <sup>1</sup> (Bar)	(L) Length (mm)	(R) Radius (mm)	Article number	Product name	Execution <sup>2</sup> S/W	Stock <sup>3</sup> ○ / ●
6,00 x 1,00 mm	-	-	-	-	-	CQE	S	- <sup>4</sup>
8,00 x 1,00 mm	-	-	-	-	-	CQE	S	- <sup>4</sup>
10,00 x 1,00 mm	-	-	-	-	-	CQE	S	- <sup>4</sup>
12,00 x 1,00 mm	-	-	-	-	1310443	CQE	S	- <sup>4</sup>
18,00 x 1,50 mm	-	-	-	-	1310801	CQE	S	○
28,00 x 1,50 mm	-	-	-	-	1311323	CQE	S	○

<sup>1)</sup> Maximum operating pressure at maximum 20 C° according to EN 13480-3 <sup>2)</sup> Execution: S = Manufactured from seamless tubes W = Manufactured from welded tubes  
<sup>3)</sup> ● = Stock standard product, ○ = Made to order <sup>4)</sup> Special request

# CALAMO – CQE – EQUAL TEE

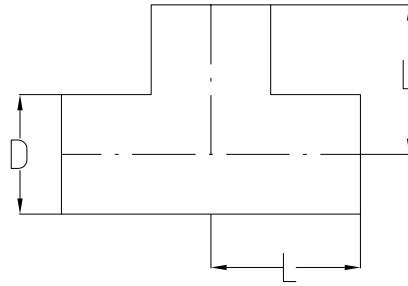

DN	(D) x wall (mm)	Weight (Kg/m)	Pressure <sup>1</sup> (Bar)	(L) Length (mm)	Article number	Product name	Execution <sup>2</sup> S/W	Stock <sup>3</sup> ○ / ●
8	6,35 x 0,89 mm 1/4 x 0.035"	0,011	215	45	1304120NL	CQE	S	○
10	9,53 x 0,89 mm 3/8 x 0.035"	0,025	123	45	1304280NL	CQE	S	○
15	12,70 x 1,24 mm 1/2 x 0.049"	0,055	131	48	1304560NL	CQE	S	○
20	19,05 x 1,65 mm 3/4 x 0.065"	0,110	111	51	1304880NL	CQE	S	○
25	25,40x1,65 mm 1 x 0.065"	0,175	75	54	1305160NL	CQE	S	○
40	38,1 x 1,65 mm 1 1/2 x 0.065"	0,282	44	60	1335480	CQE	W	○
50	50,8 x 1,65 mm 2 x 0.065"	0,454	30	73	1305680NL	CQE	W	○
65	63,5 x 1,65 mm 2 1/2 x 0.065"	0,588	22	79	1335780NL	CQE	W	○
80	76,2 x 1,65 mm 3 x 0.065"	0,755	17	86	1335820NL	CQE	W	○
100	101,60 x 2,11 mm 4 x 0.083"	1,423	16	105	1336000NL	CQE	W	○
150	152,4 x 2,77 mm 6 x 0.109"	3,907	14	143	1336100NL	CQE	W	○

<sup>1)</sup> Maximum operating pressure at maximum 20 C° according to EN 13480-3 <sup>2)</sup> Execution: S = Manufactured from seamless tubes W = Manufactured from welded tubes  
<sup>3)</sup> ● = Stock standard product, ○ = Made to order

# CALAMO – CQE – EQUAL TEE

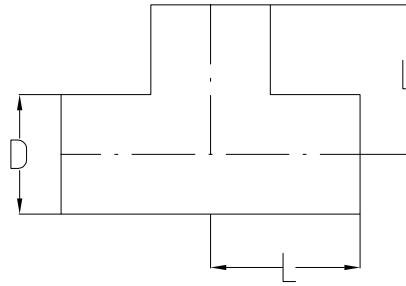

(D) x wall (mm)	Weight (Kg/m)	Pressure <sup>1</sup> (Bar)	(L) Length (mm)	Article number	Product name	Execution <sup>2</sup> S/W	Stock <sup>3</sup> ○ / ●
6,00 x 1,00 mm	0,013	304	35	1304040L	CQE	S	●
8,00 x 1,00 mm	0,027	204	54	1304200L	CQE	S	●
10,00 x 1,00 mm	0,036	151	55	1304360L	CQE	S	●
12,00 x 1,00 mm	0,044	118	35	1304440	CQE	S	●
12,00 x 1,00 mm	0,044	118	56	1304440L	CQE	S	●
15,00 x 1,00 mm	0,058	59	59	1304700L	CQE	S	●
18,00 x 1,50 mm	0,103	131	59	1304800L	CQE	S	●
22,00 x 1,50 mm	-	79	64	1304977L	CQE	S	●
28,00 x 1,50 mm	0,176	72	64	1305320L	CQE	S	●
35,00 x 1,50 mm	-	56	68	1335440L	CQE	W	●

<sup>1)</sup> Maximum operating pressure at maximum 20 C° according to EN 13480-3 <sup>2)</sup> Execution: S = Manufactured from seamless tubes W = Manufactured from welded tubes  
<sup>3)</sup> ● = Stock standard product, ○ = Made to order

# CALAMO – CQE – UNEQUAL TEE

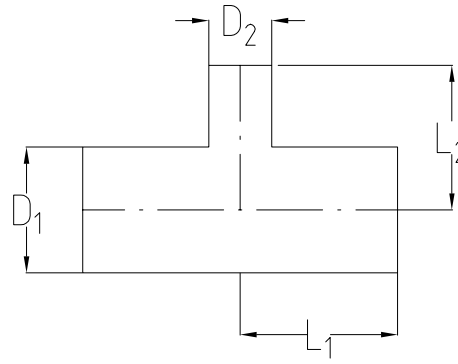

DN	(D1) x wall (mm)	(D2) x wall (mm)	Weight (Kg/m)	Pressure <sup>1</sup> (Bar)	(L1) Length (mm)	(L2) Length (mm)	Article number	Product name	Execution <sup>2</sup> S/W	Stock <sup>3</sup> ○ / ●
10/8	9,53 x 0,89 mm 3/8 x 0.035"	6,35 x 0,89 mm 1/4 x 0.035"	0,222	158	45	45	1304281US	CQE	S	○
15/8	12,70 x 1,24 mm 1/2 x 0.049"	6,35 x 0,89 mm 1/4 x 0.035"	0,044	163	48	48	1304561	CQE	S	○
15/10	12,70 x 1,24 mm 1/2 x 0.049"	9,53 x 0,89 mm 3/8 x 0.035"	0,047	130	48	48	1304562	CQE	S	○
20/8	19,05 x 1,65 mm 3/4 x 0.065"	6,35 x 0,89 mm 1/4 x 0.035"	0,083	149	51	51	1304881NL	CQE	S	○
20/10	19,05 x 1,65 mm 3/4 x 0.065"	9,53 x 0,89 mm 3/8 x 0.035"	0,086	123	51	51	1304882US	CQE	S	○
20/15	19,05 x 1,65 mm 3/4 x 0.065"	12,70 x 1,24 mm 1/2 x 0.049"	0,093	121	51	51	1304883	CQE	S	○
25/8	25,40 x 1,65 mm 1 x 0.065"	6,35 x 0,89mm 1/4 x 0.035"	0,131	115	54	54	1305161	CQE	S	○
25/10	25,40 x 1,65 mm 1 x 0.065"	9,53 x 0,89 mm 3/8 x 0.035"	0,131	98	54	54	1304882US	CQE	S	○
25/15	25,40 x 1,65 mm 1 x 0.065"	12,70 x 1,24 mm 1/2 x 0.049"	0,135	97	54	54	1304883	CQE	S	○
25/20	25,40 x 1,65 mm 1 x 0.065"	19,05 x 1,65 mm 3/4 x 0.065"	0,256	91	54	54	1305166	CQE	S	○

<sup>1)</sup> Maximum operating pressure at maximum 20 C° according to EN 13480-3 <sup>2)</sup> Execution: S = Manufactured from seamless tubes W = Manufactured from welded tubes  
<sup>3)</sup> ● = Stock standard product, ○ = Made to order

# CALAMO – CQE – UNEQUAL TEE

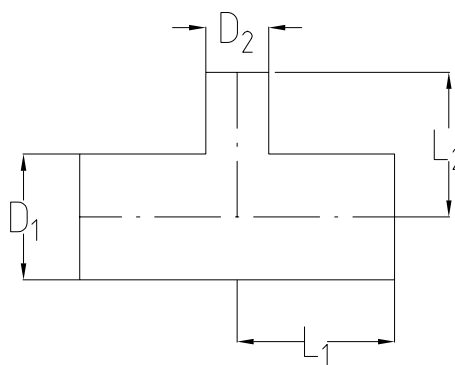

DN	(D1) x wall (mm)	(D2) x wall (mm)	Weight (Kg/m)	Pressure <sup>1</sup> (Bar)	(L1) Length (mm)	(L2) Length (mm)	Article number	Product name	Execution <sup>2</sup> S/W	Stock <sup>3</sup> ○ / ●
40/15	38,1 x 1,65 mm 1 1/2 x 0.065"	12,70 x 1,24 mm 1/2 x 0.049"	-	-	-	-	-	CQE	W	○
40/20	38,1 x 1,65 mm 1 1/2 x 0.065"	19,05 x 1,65 mm 3/4 x 0.065"	-	-	-	-	-	CQE	W	○
40/25	38,1 x 1,65 mm 1 1/2 x 0.065"	25,40 x 1,65 mm 1 x 0.065"	-	-	-	-	-	CQE	W	○
50/15	50,8 x 1,65 mm 2 x 0.065"	12,70 x 1,24 mm 1/2 x 0.049"	-	-	-	-	-	CQE	W	○
50/20	50,8 x 1,65 mm 2 x 0.065"	19,05 x 1,65 mm 3/4 x 0.065"	-	-	-	-	1305686	CQE	W	○
50/25	50,8 x 1,65 mm 2 x 0.065"	25,40 x 1,65 mm 1 x 0.065"	-	-	-	-	1305688NL	CQE	W	○
50/40	50,8 x 1,65 mm 2 x 0.065"	38,1 x 1,65 mm 1 1/2 x 0.065"	-	-	-	-	1305690NL	CQE	W	○
65/15	63,5 x 1,65 mm 2 1/2 x 0.065"	12,70 x 1,24 mm 1/2 x 0.049"	-	-	-	-	-	CQE	W	○
65/20	63,5 x 1,65 mm 2 1/2 x 0.065"	19,05 x 1,65 mm 3/4 x 0.065"	0,486	38	73	73	1335796	CQE	W	○
65/25	63,5 x 1,65 mm 2 1/2 x 0.065"	25,40 x 1,65 mm 1 x 0.065"	0,501	38	73	73	1335801	CQE	W	○
65/40	63,5 x 1,65 mm 2 1/2 x 0.065"	38,1 x 1,65 mm 1 1/2 x 0.065"	0,531	30	73	73	1335804	CQE	W	○
65/50	63,5 x 1,65 mm 2 1/2 x 0.065"	50,8 x 1,65 mm 2 x 0.065"	0,723	25	73	73	1335807	CQE	W	○
80/15	76,2 x 1,65 mm 3 x 0.065"	12,70 x 1,24 mm 1/2 x 0.049"	0,601	32	79	79	1335823NL	CQE	W	○
80/20	76,2 x 1,65 mm 3 x 0.065"	19,05 x 1,65 mm 3/4 x 0.065"	0,622	32	79	79	1335824NL	CQE	W	○
80/25	76,2 x 1,65 mm 3 x 0.065"	25,40 x 1,65 mm 1 x 0.065"	0,636	32	79	79	1335825NL	CQE	W	○
80/40	76,2 x 1,65 mm 3 x 0.065"	38,1 x 1,65 mm 1 1/2 x 0.065"	0,666	26	79	79	1335826NL	CQE	W	○
80/50	76,2 x 1,65 mm 3 x 0.065"	50,8 x 1,65 mm 2 x 0.065"	0,696	22	79	79	1335827NL	CQE	W	○
80/65	76,2 x 1,65 mm 3 x 0.065"	63,5 x 1,65 mm 2 1/2 x 0.065"	0,723	19	79	79	1335839	CQE	W	○

<sup>1)</sup> Maximum operating pressure at maximum 20 C° according to EN 13480-3 <sup>2)</sup> Execution: S = Manufactured from seamless tubes W = Manufactured from welded tubes  
<sup>3)</sup> ● = Stock standard product, ○ = Made to order

# CALAMO – CQE – UNEQUAL TEE

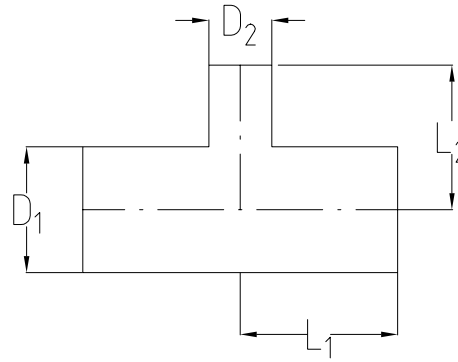

DN	(D1) x wall (mm)	(D2) x wall (mm)	Weight (Kg/m)	Pressure <sup>1</sup> (Bar)	(L1) Length (mm)	(L2) Length (mm)	Article number	Product name	Execu- tion <sup>2</sup> S/W	Stock <sup>3</sup> ○ / ●
100/25	101,60 x 2,11 mm 4 x 0.083"	25,40 x 1,65 mm 1 x 0.065"	1,181	31	108	108	1336011NL	CQE	W	○
100/40	101,60 x 2,11 mm 4 x 0.083"	38,1 x 1,65 mm 1 1/2 x 0.065"	1,211	26	108	108	1336014NL	CQE	W	○
100/50	101,60 x 2,11 mm 4 x 0.083"	50,8 x 1,65 mm 2 x 0.065"	1,241	22	108	108	1336018NL	CQE	W	○
100/65	101,60 x 2,11 mm 4 x 0.083"	63,5 x 1,65 mm 2 1/2 x 0.065"	-	-	-	-	-	CQE	W	○
100/80	101,60 x 2,11 mm 4 x 0.083"	76,2 x 1,65 mm 3 x 0.065"	1,300	17	108	108	1336022NL	CQE	W	○
150/50	152,4 x 2,77 mm 6 x 0.109"	50,8 x 1,65 mm 2 x 0.065"	3,281	21	152	152	1336124NL	CQE	W	○
150/80	152,4 x 2,77 mm 6 x 0.109"	76,2 x 1,65 mm 3 x 0.065"	-	-	-	-	-	CQE	W	○
150/100	152,4 x 2,77 mm 6 x 0.109"	101,60 x 2,11 mm 4 x 0.083"	3,522	14	152	152	1336130NL	CQE	W	○

<sup>1)</sup> Maximum operating pressure at maximum 20 C° according to EN 13480-3 <sup>2)</sup> Execution: S = Manufactured from seamless tubes W = Manufactured from welded tubes  
<sup>3)</sup> ● = Stock standard product, ○ = Made to order

# CALAMO – CQE – UNEQUAL TEE

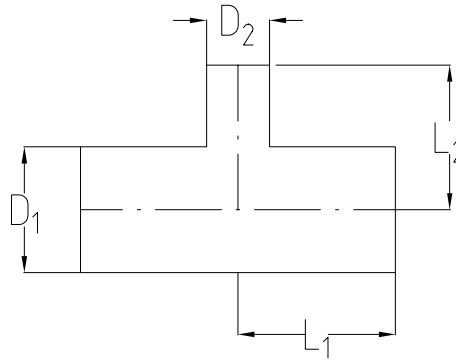

(D1) x wall (mm)	(D2) x wall (mm)	Weight (Kg/m)	Pressure <sup>1</sup> (Bar)	(L1) Length (mm)	(L2) Length (mm)	Article number	Product name	Execution <sup>2</sup> S/W	Stock <sup>3</sup> ○ / ●
8,00 x 1,00 mm	6,00 x 1,00 mm	0,025	245	30	30	1304201	CQE	S	○
10,00 x 1,00 mm	6,00 x 1,00 mm	0,031	205	30	30	1304361	CQE	S	○
10,00 x 1,00 mm	8,00 x 1,00 mm	0,033	174	30	30	1304363	CQE	S	○
12,00 x 1,00 mm	6,00 x 1,00 mm	0,037	176	56	56	1304441L	CQE	S	●
12,00 x 1,00 mm	8,00 x 1,00 mm	0,039	151	56	56	1304442L	CQE	S	●
12,00 x 1,00 mm	10,00 x 1,00 mm	0,042	133	56	56	1304443L	CQE	S	●
15,00 x 1,00 mm	10,00 x 1,00 mm	-	-	56	56	1304687L	CQE	S	○
15,00 x 1,00 mm	12,00 x 1,00 mm	-	-	56	56	1304688	CQE	S	●
18,00 x 1,00 mm	15,00 x 1,00 mm	-	-	59	59	1304807	CQE	S	●
18,00 x 1,50 mm	6,00 x 1,00 mm	0,079	185	35	35	1304801	CQE	S	●
18,00 x 1,50 mm	8,00 x 1,00 mm	0,081	163	35	35	1304802	CQE	S	○
18,00 x 1,50 mm	10,00 x 1,00 mm	0,084	145	59	59	1304803L	CQE	S	○
18,00 x 1,50 mm	12,00 x 1,00 mm	0,140	130	59	59	1304804L	CQE	S	●
22,00 x 1,50 mm	12,00 x 1,00 mm	0,107	86	64	64	1304980L	CQE	S	●
22,00 x 1,50 mm	15,00 x 1,00 mm	0,111	75	64	64	1304982L	CQE	S	●
22,00 x 1,50 mm	18,00 x 1,50 mm	0,125	91	64	64	1304985L	CQE	S	●
28,00 x 1,50 mm	12,00 x 1,00 mm	0,140	93	64	64	1305324L	CQE	S	●
28,00 x 1,50 mm	18,00 x 1,50 mm	0,157	95	64	64	1305327L	CQE	S	●

<sup>1)</sup> Maximum operating pressure at maximum 20 C° according to EN 13480-3 <sup>2)</sup> Execution: S = Manufactured from seamless tubes W = Manufactured from welded tubes  
<sup>3)</sup> ● = Stock standard product, ○ = Made to order



# CALAMO – CQE – CONCENTRIC REDUCER

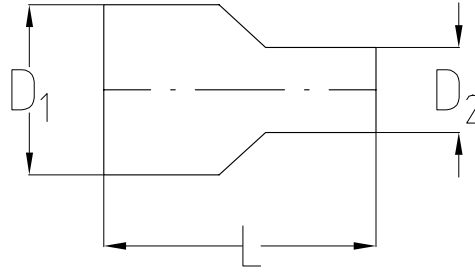

DN	(D1) x wall (mm)	(D2) x wall (mm)	Weight (Kg/m)	Pressure <sup>1</sup> (Bar)	(L1) Length (mm)	Article number	Product name	Execution <sup>2</sup> B/P	Stock <sup>3</sup> ○ / ●
10/8	9,53 x 0,89 mm 3/8 x 0.035"	6,35 x 0,89 mm 1/4 x 0.035"	0,050	-	-	1307281	CQE	B	○
15/8	12,70 x 1,24 mm 1/2 x 0.049"	6,35 x 0,89 mm 1/4 x 0.035"	0,050	-	-	1307560	CQE	B	○
15/10	12,70 x 1,24 mm 1/2 x 0.049"	9,53 x 0,89 mm 3/8 x 0.035"	0,050	-	-	1307561	CQE	B	○
20/8	19,05 x 1,65 mm 3/4 x 0.065"	6,35 x 0,89 mm 1/4 x 0.035"	0,075	-	-	1307881	CQE	B	○
20/10	19,05 x 1,65 mm 3/4 x 0.065"	9,53 x 0,89 mm 3/8 x 0.035"	0,075	-	-	1307882	CQE	B	○
20/15	19,05 x 1,65 mm 3/4 x 0.065"	12,70 x 1,24 mm 1/2 x 0.049"	0,075	-	-	1307883	CQE	B	○
25/8	25,40 x 1,65 mm 1 x 0.065"	6,35 x 0,89mm 1/4 x 0.035"	0,100	-	-	1308160	CQE	B	○
25/10	25,40 x 1,65 mm 1 x 0.065"	9,53 x 0,89 mm 3/8 x 0.035"	0,100	-	-	1308161	CQE	B	○
25/15	25,40 x 1,65 mm 1 x 0.065"	12,70 x 1,24 mm 1/2 x 0.049"	0,100	-	-	1308163	CQE	B	○
25/20	25,40 x 1,65 mm 1 x 0.065"	19,05 x 1,65 mm 3/4 x 0.065"	0,100	-	-	1308168	CQE	B	○
40/15	38,1 x 1,65 mm 1 1/2 x 0.065"	12,70 x 1,24 mm 1/2 x 0.049"	0,125	-	-	1308484	CQE	B	○
40/20	38,1 x 1,65 mm 1 1/2 x 0.065"	19,05 x 1,65 mm 3/4 x 0.065"	0,125	-	-	1308485	CQE	B	○
40/25	38,1 x 1,65 mm 1 1/2 x 0.065"	25,40 x 1,65 mm 1 x 0.065"	0,125	-	-	1308486	CQE	B	○
50/15	50,8 x 1,65 mm 2 x 0.065"	12,70 x 1,24 mm 1/2 x 0.049"	0,300	-	-	1309681	CQE	B	○
50/20	50,8 x 1,65 mm 2 x 0.065"	19,05 x 1,65mm 3/4 x 0.065"	0,300	-	-	1309685	CQE	B	○
50/25	50,8 x 1,65 mm 2 x 0.065"	25,40 x 1,65 mm 1 x 0.065"	0,300	-	-	1309687	CQE	B	○
50/40	50,8 x 1,65 mm 2 x 0.065"	38,1 x 1,65 mm 1 1/2 x 0.065"	0,300	-	-	1309689	CQE	B	○

<sup>1)</sup> Maximum operating pressure at maximum 20 C° according to EN 13480-3 <sup>2)</sup> B = Manufactured from solid bar, P = Pressed plat

<sup>3)</sup> ● = Stock standard product, ○ = Made to order

# CALAMO – CQE – CONCENTRIC REDUCER

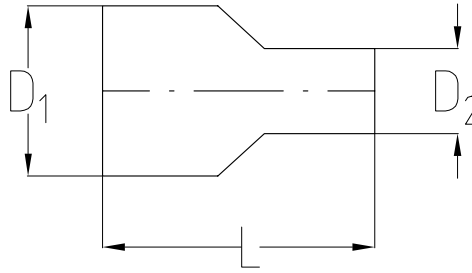

DN	(D1) x wall (mm)	(D2) x wall (mm)	Weight (Kg/m)	Pressure <sup>1</sup> (Bar)	(L1) Length (mm)	Article number	Product name	Execution <sup>2</sup> B/P	Stock <sup>3</sup> ○ / ●
65/15	63,5 x 1,65 mm 2 1/2 x 0.065"	12,70 x 1,24 mm 1/2 x 0.049"	-	-	-	-	CQE	B	○
65/20	63,5 x 1,65 mm 2 1/2 x 0.065"	19,05 x 1,65 mm 3/4 x 0.065"	-	-	-	-	CQE	B	○
65/25	63,5 x 1,65 mm 2 1/2 x 0.065"	25,40 x 1,65 mm 1 x 0.065"	0,500	-	-	1309810	CQE	B	○
65/40	63,5 x 1,65 mm 2 1/2 x 0.065"	38,1 x 1,65 mm 1 1/2 x 0.065"	0,500	-	-	1309814	CQE	B	○
65/50	63,5 x 1,65 mm 2 1/2 x 0.065"	50,8 x 1,65 mm 2 x 0.065"	0,500	-	-	1309816	CQE	B	○
80/15	76,2 x 1,65 mm 3 x 0.065"	12,70 x 1,24 mm 1/2 x 0.049"	-	-	-	-	CQE	B	○
80/20	76,2 x 1,65 mm 3 x 0.065"	19,05 x 1,65 mm 3/4 x 0.065"	0,750	-	-	1309821	CQE	B	○
80/25	76,2 x 1,65 mm 3 x 0.065"	25,40 x 1,65 mm 1 x 0.065"	0,750	-	-	1309822	CQE	B	○
80/40	76,2 x 1,65 mm 3 x 0.065"	38,1 x 1,65 mm 1 1/2 x 0.065"	0,750	-	-	1309823	CQE	B	○
80/50	76,2 x 1,65 mm 3 x 0.065"	50,8 x 1,65 mm 2 x 0.065"	0,750	-	-	1309824	CQE	B	○
80/65	76,2 x 1,65 mm 3 x 0.065"	63,5 x 1,65 mm 2 1/2 x 0.065"	0,750	-	-	1309827	CQE	B	○
100/25	101,60 x 2,11 mm 4 x 0.083"	25,40 x 1,65 mm 1 x 0.065"	0,890	-	-	1309910	CQE	B	○
100/40	101,60 x 2,11 mm 4 x 0.083"	38,1 x 1,65 mm 1 1/2 x 0.065"	0,890	-	-	1309912	CQE	B	○
100/50	101,60 x 2,11 mm 4 x 0.083"	50,8 x 1,65 mm 2 x 0.065"	0,890	-	-	1309913	CQE	B	○
100/65	101,60 x 2,11 mm 4 x 0.083"	63,5 x 1,65 mm 2 1/2 x 0.065"	-	-	-	-	CQE	B	○
100/80	101,60 x 2,11 mm 4 x 0.083"	76,2 x 1,65 mm 3 x 0.065"	0,890	-	-	1309917	CQE	B	○
150/50	152,4 x 2,77 mm 6 x 0.109"	50,8 x 1,65 mm 2 x 0.065"	1,200	-	-	1309940	CQE	B	○
150/80	152,4 x 2,77 mm 6 x 0.109"	76,2 x 1,65 mm 3 x 0.065"	-	-	-	-	CQE	B	○
150/100	152,4 x 2,77 mm 6 x 0.109"	101,60 x 2,11 mm 4 x 0.083"	1,200	-	-	1309946	CQE	B	○

<sup>1)</sup> Maximum operating pressure at maximum 20 C° according to EN 13480-3 <sup>2)</sup> B = Manufactured from solid bar, P = Pressed plat

<sup>3)</sup> ● = Stock standard product, ○ = Made to order

# CALAMO – CQE – CONCENTRIC REDUCER

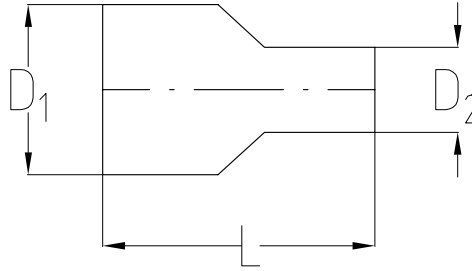

(D1) x wall (mm)	(D2) x wall (mm)	Weight (Kg/m)	Pressure <sup>1</sup> (Bar)	(L1) Length (mm)	Article number	Product name	Execution <sup>2</sup> B/P	Stock <sup>3</sup> ○ / ●
8,00 x 1,00 mm	6,00 x 1,00 mm	-	-	-	-	CQE	B	- <sup>4</sup>
10,00 x 1,00 mm	6,00 x 1,00 mm	0,050	221	-	1307340	CQE	B	- <sup>4</sup>
10,00 x 1,00 mm	8,00 x 1,00 mm	0,050	-	-	1307360	CQE	B	- <sup>4</sup>
12,00 x 1,00 mm	6,00 x 1,00 mm	0,050	176	75	1307439	CQE	B	●
12,00 x 1,00 mm	8,00 x 1,00 mm	0,050	-	-	1307442	CQE	B	- <sup>4</sup>
12,00 x 1,00 mm	10,00 x 1,00 mm	0,050	-	-	1307445	CQE	B	- <sup>4</sup>
15,00 x 1,00 mm	6,00 x 1,00 mm	-	-	-	-	CQE	B	- <sup>4</sup>
15,00 x 1,00 mm	10,00 x 1,00 mm	0,050	-	-	1307720	CQE	B	- <sup>4</sup>
15,00 x 1,00 mm	12,00 x 1,00 mm	0,050	-	75	1307722	CQE	B	●
18,00 x 1,50 mm	6,00 x 1,00 mm	0,100	107	-	1307801	CQE	B	- <sup>4</sup>
18,00 x 1,50 mm	8,00 x 1,00 mm	-	-	-	-	CQE	B	- <sup>4</sup>
18,00 x 1,50 mm	10,00 x 1,00 mm	0,100	-	38	1307803	CQE	B	○
18,00 x 1,50 mm	12,00x1,00 mm	0,100	-	-	1307805	CQE	B	●
18,00 x 1,50 mm	15,00 x 1,00 mm	0,100	119	75	1307810	CQE	B	- <sup>4</sup>
22,00 x 1,50 mm	12,00 x 1,00 mm	-	-	-	1307986	CQE	B	- <sup>4</sup>
22,00 x 1,50 mm	15,00 x 1,00 mm	0,100	-	75	1307990	CQE	B	○
22,00 x 1,50 mm	18,00 x 1,50 mm	0,100	-	75	1307994	CQE	B	●
28,00 x 1,50 mm	12,00 x 1,00 mm	0,100	-	75	1308324	CQE	B	●
28,00 x 1,50 mm	18,00 x 1,50 mm	0,100	61	75	1308327	CQE	B	●
35,00 x 1,50 mm	15,00 x 1,00 mm	0,100	-	80	1308442	CQE	B	- <sup>4</sup>
35,00 x 1,50 mm	18,00 x 1,50 mm	0,100	-	80	1308443	CQE	B	- <sup>4</sup>
35,00 x 1,50 mm	22,00 x 1,50 mm	0,100	-	80	1308447	CQE	B	- <sup>4</sup>

<sup>1)</sup> Maximum operating pressure at maximum 20 C° according to EN 13480-3 <sup>2)</sup> B = Manufactured from solid bar, P = Pressed plat  
<sup>3)</sup> ● = Stock standard product, ○ = Made to order <sup>4)</sup> Special request

# CALAMO – CQE – END CAP

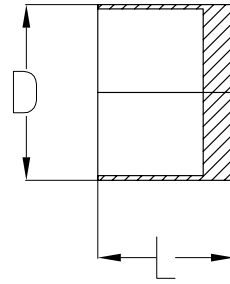

DN	(D) x wall (mm)	Weight (Kg/m)	Pressure <sup>1</sup> (Bar)	(L1) Length (mm)	Article number	Product name	Execution <sup>2</sup> B/P	Stock <sup>3</sup> ○ / ●
8	6,35 x 0,89 mm 1/4 x 0.035"	0,050	-	6	1309950	CQE	B	○
10	9,53 x 0,89 mm 3/8 x 0.035"	0,050	-	6	1309952	CQE	B	○
15	12,70 x 1,24 mm 1/2 x 0.049"	0,050	-	6	1309955	CQE	B	○
20	19,05 x 1,65 mm 3/4 x 0.065"	0,150	-	8	1309958	CQE	B	○
25	25,40 x 1,65 mm 1 x 0.065"	0,150	-	8	1309961	CQE	B	○
40	38,1 x 1,65 mm 1 1/2 x 0.065"	0,400	-	11	1309969	CQE	B	○
50	50,8 x 1,65 mm 2 x 0.065"	0,400	-	11	1309975	CQE	B	○
65	63,5 x 1,65mm 2 1/2 x 0.065"	-	-	-	-	CQE	B	○
80	76,2 x 1,65mm 3 x 0.065"	1,500	-	11	1309980	CQE	B	○
100	101,60 x 2,11 mm 4 x 0.083"	2,500	-	13	1309985	CQE	B	○
150	152,4 x 2,77 mm 6 x 0.109"	5,500	-	30	1309991	CQE	B	○

<sup>1)</sup> Maximum operating pressure at maximum 20 C° according to EN 13480-3 <sup>2)</sup> B = Manufactured from solid bar, P = Pressed plat  
<sup>3)</sup> ● = Stock standard product, ○ = Made to order

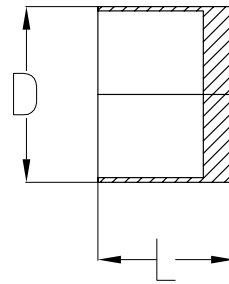

(D) x wall (mm)	Weight (Kg/m)	Pressure <sup>1</sup> (Bar)	(L1) Length (mm)	Article number	Product name	Execution <sup>2</sup> B/P	Stock <sup>3</sup> ○ / ●
6,00 x 1,00 mm	-	-	-	-	CQE	B	○
8,00 x 1,00 mm	-	-	-	-	CQE	B	○
10,00 x 1,00 mm	-	-	-	-	CQE	B	○
12,00 x 1,00 mm	-	-	-	-	CQE	B	○
18,00 x 1,50 mm	-	-	-	-	CQE	B	○
28,00 x 1,50 mm	-	-	-	-	CQE	B	○

<sup>1)</sup> Maximum operating pressure at maximum 20 C° according to EN 13480-3 <sup>2)</sup> B = Manufactured from solid bar, P = Pressed plate  
<sup>3)</sup> ● = Stock standard product, ○ = Made to order

# CQ CLEAN TUBES

## *Stainless steel tube system* for High Purity Gas Systems

CALAMO CQ is manufactured for transporting high purity gases for laboratories, calibration gases or transport of oxygen. The manufacturing process is controlled to guarantee a stable quality from gas source to point of use.



### Products

Stainless steel tubes

- Outside diameter: 4,00 – 152,40 mm

### Standard

Steel grade: EN 1.4404/1.4435/1.4432, ASTM 316L

Seamless: EN 10216-5 TC1, ASTM A269/A270, ASME SA213

Welded: EN 10217-7 TC1, ASTM A270/A269, ASME SA 249

Tolerances: ISO 1127 D4/T3, D3/T3, D2/T3, D2/T2, ASTM A269/A270

### Specification

- Raw material
  - Seamless and welded tubes and fittings
  - Bright annealed or annealed
- Manufactured in accordance with SWID-4545
- Option: Surface roughness
- In accordance with ASTM G93



### Certificate

CALAMO is certified in accordance with following systems (quality) ISO 9001 and (environment) ISO 14001.

### Manufacturing

- Cleanliness achieved through advanced surface treatment and packing technique.
- Final rinsing using deionized water.
- Tubes are dried with nitrogen from cryo tank.
- Individual surface control of cleanliness and surfaces.
- CQ-tubes are sealed with polyethylene caps and individually packed in polyethylene sleeves.

### Advantages

- Products are cleaned to transport high purity gases without interference with the process.
- Products are protected from contamination.
- Products have full traceability from steel melt to customer. Material certificate according to EN 10204 3.1.
- Each polyethylene sleeve is marked with a unique label that can be traced back to the certificate.
- The CQ-tubes fulfill the requirements according to PED 2014/68/EU and AFS 2016:1.
- A large stock of finished tubes safeguard short lead times and quick installations.
- CQ is prepared for orbital welding.
- CQ tubes with OD below 6-18 mm can be bent on-site with same cleanliness and durability.
- A large stock of finished tubes guarantee high service and short lead times.

# CALAMO - CQ - TUBE

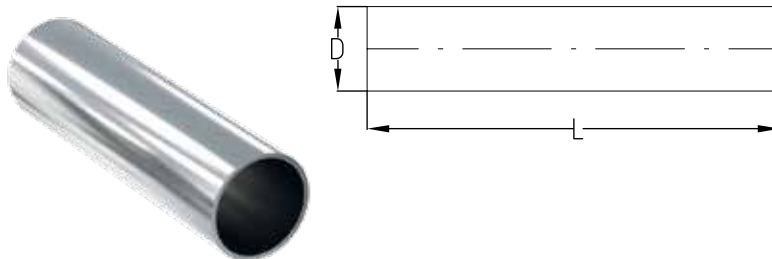

(L) Nominal length 6 000 mm for execution S

(L) Nominal length 6 100 mm for execution W

DN	(D) x wall (mm)	Weight (Kg/m)	Pressure <sup>1</sup> (Bar)	Article number	Product name	Execution <sup>2</sup> S/W	Stock <sup>3</sup> ○ / ●
8	6,35 x 0,89 mm 1/4 x 0.035"	0,123	331	0400120	CQ	S	●
10	9,53 x 0,89 mm 3/8 x 0.035"	0,195	210	0400240	CQ	S	○
15	12,70 x 1,24 mm 1/2 x 0.049"	0,353	221	0400560	CQ	S	●
15	12,70 x 1,65 mm 1/2 x 0.065"	0,453	383	0400600	CQ	S	○
20	19,05 x 1,65mm 3/4 x 0.065"	0,719	194	0400880	CQ	S	●
25	25,40 x 1,65mm 1 x 0.065"	0,974	182	0401160	CQ	S	●
25	25,40 x 1,65mm 1 x 0.065"	-	-	0441170	CQ	W	●
40	38,1 x 1,65mm 1 1/2 x 0.065"	1,500	93	0441480	CQ	W	●
50	50,8 x 1,65mm 2 x 0.065"	2,030	69	0441680	CQ	W	○
65	63,5 x 1,65mm 2 1/2 x 0.065"	2,500	38	0441778	CQ	W	○
80	76,2 x 1,65mm 3 x 0.065"	3,056	46	0441820	CQ	W	○
100	101,60 x 2,11mm 4 x 0.083"	5,210	31	0442000	CQ	W	○
150	152,4 x 2,77mm 6 x 0.109"	10,287	27	0462050	CQ	W	○

<sup>1)</sup> Maximum operating pressure at maximum 20 C° according to EN 13480-3 <sup>2)</sup> Execution: S = Manufactured from seamless tubes W = Manufactured from welded tubes

<sup>3)</sup> ● = Stock standard product, ○ = Made to order

# CALAMO - CQ - TUBE

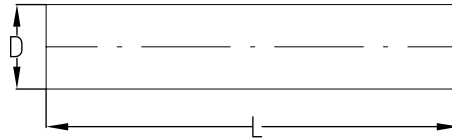

(L) Nominal length 6 000 mm

(D) x wall (mm)	Weight (Kg/m)	Pressure <sup>1</sup> (Bar)	Article number	Product name	Execution <sup>2</sup> S/W	Stock <sup>3</sup> ○ / ●
4,00 x 1,00 mm	0,074	-	0900425	CQ	S	●
6,00 x 1,00 mm	0,124	462	0400040	CQ	S	●
8,00 x 1,00 mm	0,174	333	0400200	CQ	S	●
10,00 x 1,00 mm	0,223	261	0400360	CQ	S	●
10,00 x 1,50 mm	0,319	443	0400400	CQ	S	○
10,00 x 2,00 mm	0,397	650	0400421	CQ	S	○
12,00 x 1,00 mm	0,273	214	0400440	CQ	S	●
12,00 x 1,50 mm	0,394	361	0400480	CQ	S	●
15,00 x 1,00 mm	0,350	125	0400700	CQ	S	●
15,00 x 1,50 mm	0,503	282	0400710	CQ	S	○
18,00 x 1,50 mm	0,615	234	0400810	CQ	S	●
18,00 x 2,00 mm	0,794	331	0400835	CQ	S	○
22,00 x 1,50 mm	0,769	157	0400990	CQ	S/W	○
28,00 x 1,50 mm	0,987	146	0401321	CQ	S/W	●

<sup>1)</sup> Maximum operating pressure at maximum 20 C° according to EN 13480-3 <sup>2)</sup> Execution: S = Manufactured from seamless tubes W = Manufactured from welded tubes  
<sup>3)</sup> ● = Stock standard product, ○ = Made to order





## COILED TUBING ACCORDING TO ASTM G93

CALAMO stainless steel Coiled tubing is manufactured for transporting high purity gases for laboratories, calibration gases and transport of oxygen, (CFOS), for laboratories. The manufacturing process is controlled to guarantee a stable quality from gas source to point of use.

DN	(D) x wall (mm)	Weight (Kg/m)	Pressure <sup>1</sup> (Bar)	Article number	Product name	Execution <sup>2</sup> S/W	Stock <sup>3</sup> ○ / ●
6	3,18 x 0,50 mm 1/8 x 0.020"	0,034	-	0900320	CFOS	S	●

<sup>1)</sup> Maximum operating pressure at maximum 20 C° according to EN 13480-3 <sup>2)</sup> Execution: S = Manufactured from seamless tubes W = Manufactured from welded tubes  
<sup>3)</sup> ● = Stock standard product, ○ = Made to order

# CQM MEDICAL

## *Stainless steel tube system* for Medical Gas Application

CALAMO CQM Medical is manufactured for transporting medical gases in hospitals. The manufacturing process is controlled to guarantee a stable quality focusing on patient safety and hospital environment.



### Products

Stainless steel tubes, tees, reducers, elbows in stainless steel including adaptors to copper.

- Outside diameter: 6,00 – 114,30 mm

### Standard

Steel grade: EN 1.4404/1.4435/1.4432, ASTM 316L

Seamless: EN 10216-5 TC1, ASTM A269/A270, ASME SA213

Welded: EN 10217-7 TC1, ASTM A270/A269, ASME SA 249

Tolerances: ISO 1127 D4/T3, D3/T3, D2/T3, D2/T2, ASTM A269/A270

### Specification

- CQM Medical
  - Surface treatment according to SWID-760
  - Hydrocarbon content < 2,5 mg/m<sup>2</sup>
- In accordance with ASTM G93
- Other tubes and fittings can on request be delivered with hydrocarbon content < 2,5mg/m<sup>2</sup>



### Certificate

CALAMO is certified in accordance with following systems (quality) ISO 9001 and (environment) ISO 14001.

### Manufacturing

- Cleanliness achieved through advanced surface treatment and packing technique. Analysis of surfaces according to SS-EN 723.
- Final rinsing always using deionized water.
- Tubes are dried with nitrogen from cryo tank.
- CQM-tubes are sealed with polyethylene caps. Fittings are packed in polyethylene bags.

### Advantages

- Tubes fulfill the cleanliness requirement of SIS hand book 370 safety standard applicable to medical gas applications and ISO 7396-1 Medical gas pipe line systems.
- Products are protected from contamination.
- Products have full traceability from steel melt to product. Material certificate according to EN 10204 3.1.
- Each polyethylene sleeve is marked with a unique label that can be traced back to the certificate.
- The products, excluding Tees, fulfill the requirements according to PED 2014/68/EU. Tees on request.
- The products fulfill AFS 2016:1.
- A large stock of finished tubes and fittings safeguard short lead times and quick installations.
- CQM Medical is prepared for orbital welding.
- CQM tubes with OD below 6-18 mm can be bent on-site with same cleanliness and durability.
- Intended as system components to be installed in medical gas installations which are only manufactured and used within health and medical institutions within the European Union (In-house manufactured medical devices). Not intended as system components in medical devices on the European Union market.

# CALAMO – CQM MEDICAL – TUBE

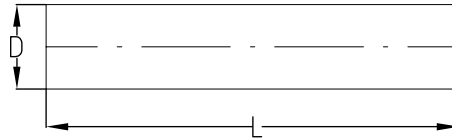

(L) Nominal length 6 000 mm for execution S

(D) x wall (mm)	Weight (Kg/m)	Pressure <sup>1</sup> (Bar)	Article number	Product name	Execution <sup>2</sup> S/W	Stock <sup>3</sup> ○ / ●
6,00 x 1,00 mm	0,124	462	0400030	CQM	S	●
8,00 x 1,00 mm	0,174	333	0400203	CQM	S	●
10,00 x 1,00 mm	0,223	261	0400330	CQM	S	●
12,00 x 1,00 mm	0,273	214	0400430	CQM	S	●
15,00 x 1,00 mm	0,350	125	0400703	CQM	S	●
18,00 x 1,50 mm	0,615	234	0400805	CQM	S	●
22,00 x 1,50 mm	0,769	157	0400985	CQM	S	●
28,00 x 1,50 mm	0,987	146	0401310	CQM	S	●
35,00 x 1,50 mm	1,260	116	0441460	CQM	W	●
53,00 x 1,50 mm	1,934	75	0441655	CQM	W	○

<sup>1)</sup> Maximum operating pressure at maximum 20 C° according to EN 13480-3 <sup>2)</sup> Execution: S = Manufactured from seamless tubes W = Manufactured from welded tubes

<sup>3)</sup> ● = Stock standard product, ○ = Made to order

# CALAMO – CQM MEDICAL – TUBE

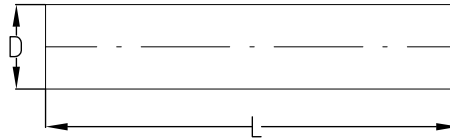

(L) Nominal length 6 000 mm

(D) x wall (mm)	Weight (Kg/m)	Pressure <sup>1</sup> (Bar)	Article number	Product name	Execution <sup>2</sup> S/W	Stock <sup>3</sup> ○ / ●
42,40 x 2,00 mm	2,000	133	0441550	CQM	W	●
48,30 x 2,00 mm	2,298	116	0441645	CQM	W	○
60,30 x 2,00 mm	2,894	92	0441770	CQM	W	●
76,10 x 2,00 mm	3,678	51	0441840	CQM	W	●
88,90 x 2,00 mm	4,313	67	0441900	CQM	W	●
88,90 x 2,30 mm	4,987	71	0441940	CQM	W	●
114,30 x 2,00 mm	5,574	47	0442020	CQM	W	●
114,30 x 2,30 mm	6,450	55	0442032	CQM	W	○

<sup>1)</sup> Maximum operating pressure at maximum 20 C° according to EN 13480-3 <sup>2)</sup> Execution: S = Manufactured from seamless tubes W = Manufactured from welded tubes  
<sup>3)</sup> ● = Stock standard product, ○ = Made to order

# CALAMO – CQM MEDICAL – ELBOW 90°

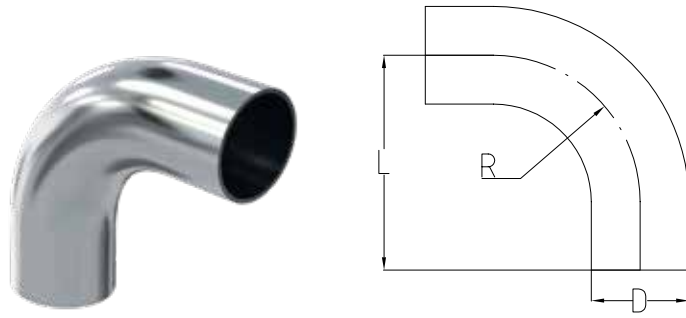

(D) x wall (mm)	Weight (Kg/m)	Pressure <sup>1</sup> (Bar)	(L) Length (mm)	(R) Radie (mm)	Article number	Product name	Execution <sup>2</sup> S/W	Stock <sup>3</sup> ○ / ●
6,00 x 1,00 mm	-	-	-	-	-	CQM	S	- <sup>4</sup>
8,00 x 1,00 mm	-	-	-	-	-	CQM	S	- <sup>4</sup>
10,00 x 1,00 mm	-	-	-	-	-	CQM	S	- <sup>4</sup>
12,00 x 1,00 mm	-	175	-	-	-	CQM	S	- <sup>4</sup>
15,00 x 1,00 mm	-	-	-	-	-	CQM	S	- <sup>4</sup>
18,00 x 1,50 mm	0,056	140	51	26	-	CQM	S	○
22,00 x 1,50 mm	0,067	134	52	40	1440984	CQM	S	○
28,00 x 1,50 mm	0,156	87	90	50	1411310	CQM	S	○
35,00 x 1,50 mm	0,212	-	95	55	1441440	CQM	W	●

<sup>1)</sup> Maximum operating pressure at maximum 20 C° according to EN 13480-3 <sup>2)</sup> Execution: S = Manufactured from seamless tubes W = Manufactured from welded tubes  
<sup>3)</sup> ● = Stock standard product, ○ = Made to order <sup>4)</sup> Special request

# CALAMO – CQM MEDICAL – ELBOW 90°

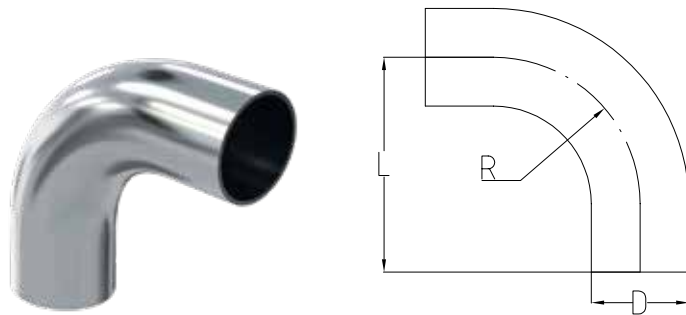

(D) x wall (mm)	Weight (Kg/m)	Pressure <sup>1</sup> (Bar)	(L) Length (mm)	(R) Radius (mm)	Article number	Product name	Execution <sup>2</sup> S/W	Stock <sup>3</sup> ○ / ●
42,40 x 2,00 mm <sup>4</sup>	-	-	-	64	1441550K	CQM	W	○
42,40 x 2,00 mm	0,311	86	88	48	1441550	CQM	W	○
48,30 x 2,00 mm <sup>4</sup>	-	-	-	-	-	CQM	W	○
48,30 x 2,00 mm	-	-	97	57	1441640	CQM	W	○
60,30 x 2,00 mm <sup>4</sup>	-	-	-	90	1441760K	CQM	W	○
60,30 x 2,00 mm	-	-	116	76	1441760	CQM	W	●
76,10 x 2,00 mm <sup>4</sup>	-	-	-	-	1441840K	CQM	W	○
76,10 x 2,00 mm	0,953	33	150	95	1441840	CQM	W	○
88,90 x 2,00 mm <sup>4</sup>	-	-	-	133	1441850K	CQM	W	●
88,90 x 2,30 mm	1,551	43	114	114	1441854	CQM	W	○
114,30 x 2,00 mm <sup>4</sup>	-	-	-	-	1442040K	CQM	W	○
114,30 x 2,30 mm	2,669	37	152	171	1442040	CQM	W	○

<sup>1</sup>) Maximum operating pressure at maximum 20 C° according to EN 13480-3 <sup>2</sup>) Execution: S = Manufactured from seamless tubes W = Manufactured from welded tubes  
<sup>3</sup>) ● = Stock standard product, ○ = Made to order <sup>4</sup>) No straight ends for orbital welding

# CALAMO – CQM MEDICAL – ELBOW 45°

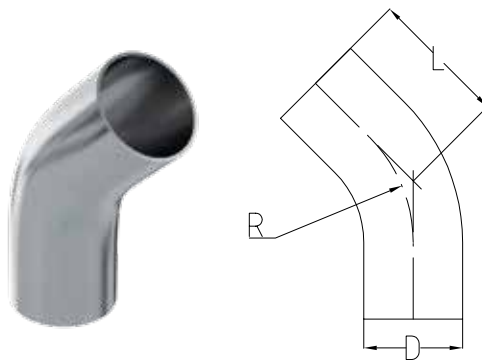

(D) x wall (mm)	Weight (Kg/m)	Pressure <sup>1</sup> (Bar)	(L) Length (mm)	(R) Radius (mm)	Article number	Product name	Execution <sup>2</sup> S/W	Stock <sup>3</sup> ○ / ●
6,00 x 1,00 mm	-	86	-	-	-	CQM	S	- <sup>4</sup>
8,00 x 1,00 mm	-	-	-	-	-	CQM	S	- <sup>4</sup>
10,00 x 1,00 mm	-	-	-	-	-	CQM	S	- <sup>4</sup>
12,00 x 1,00 mm	-	-	-	-	-	CQM	S	- <sup>4</sup>
15,00 x 1,00 mm	-	-	-	-	-	CQM	S	- <sup>4</sup>
18,00 x 1,50 mm	0,043	140	51	36	-	CQM	S	○
22,00 x 1,50 mm	-	-	-	-	-	CQM	S	○
28,00 x 1,50 mm	0,118	87	90	61	1411313	CQM	S	○
35,00 x 1,50 mm	0,163	-	63	55	1441441	CQM	W	○

<sup>1)</sup> Maximum operating pressure at maximum 20 C° according to EN 13480-3 <sup>2)</sup> Execution: S = Manufactured from seamless tubes W = Manufactured from welded tubes  
<sup>3)</sup> ● = Stock standard product, ○ = Made to order <sup>4)</sup> No straight ends for orbital welding

# CALAMO – CQM MEDICAL – ELBOW 45°

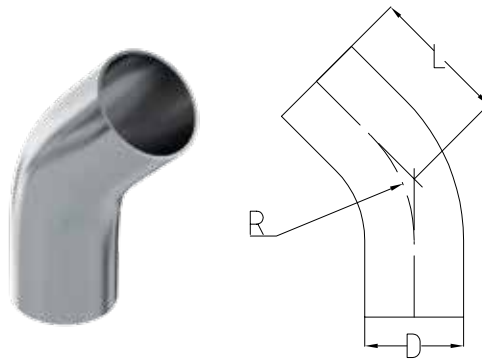

(D) x wall (mm)	Weight (Kg/m)	Pressure <sup>1</sup> (Bar)	(L) Length (mm)	(R) Radius (mm)	Article number	Product name	Execution <sup>2</sup> S/W	Stock <sup>3</sup> ○ / ●
42,40 x 2,00 mm	0,315	25	60	48	1441551	CQM	W	○
48,30 x 2,00 mm	-	-	64	57	1441641	CQM	W	○
60,30 x 2,00 mm <sup>4</sup>	-	-	-	-	1441763K	CQM	W	○
60,30 x 2,00 mm	-	-	72	76	1441761	CQM	W	○
76,10 x 2,00 mm	0,976	25	94	95	1441843	CQM	W	○
88,90 x 2,00 mm <sup>4</sup>	0,775	43	-	95	-	CQM	W	○
88,90 x 2,30 mm	-	-	102	115	1441856	CQM	W	○
114,30 x 2,00 mm <sup>4</sup>	-	-	-	-	1442041K	CQM	W	○
114,30 x 2,30 mm	1,335	37	118	153	-	CQM	W	○

<sup>1)</sup> Maximum operating pressure at maximum 20 C° according to EN 13480-3 <sup>2)</sup> Execution: S = Manufactured from seamless tubes W = Manufactured from welded tubes  
<sup>3)</sup> ● = Stock standard product, ○ = Made to order <sup>4)</sup> No straight ends for orbital welding



# CALAMO – CQM MEDICAL – EQUAL TEE

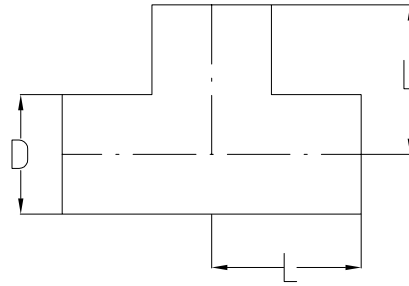

(D) x wall (mm)	Weight (Kg/m)	Pressure <sup>1</sup> (Bar)	(L) Length (mm)	Article number	Product name	Execution <sup>2</sup> S/W	Stock <sup>3</sup> ○ / ●
10,00 x 1,00 mm	-	-	-	-	CQM	S	○
12,00 x 1,00 mm	0,044	118	35	1404440L	CQM	S	○
15,00 x 1,00 mm	0,058	59	35	1404680L	CQM	S	○
18,00 x 1,50 mm	0,103	131	35	1404780L	CQM	S	○
22,00 x 1,50 mm	0,103	79	64	1404977L	CQM	S	○
28,00 x 1,50 mm	0,176	72	50	1405340L	CQM	S	○
35,00 x 1,50 mm	-	56	68	1445540L	CQM	W	○

<sup>1)</sup> Maximum operating pressure at maximum 20 C° according to EN 13480-3 <sup>2)</sup> Execution: S = Manufactured from seamless tubes W = Manufactured from welded tubes  
<sup>3)</sup> ● = Stock standard product, ○ = Made to order

# CALAMO – CQM MEDICAL – EQUAL TEE

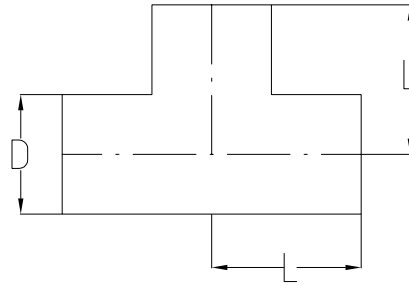

(D) x wall (mm)	Weight (Kg/m)	Pressure <sup>1</sup> (Bar)	(L) Length (mm)	Article number	Product name	Execution <sup>2</sup> S/W	Stock <sup>3</sup> ○ / ●
42,40 x 2,00 mm	0,348	64	65	1445550	CQM	W	○
42,40 x 2,00 mm <sup>4</sup>	-	-	-	1445550K	CQM	W	○
48,30 x 2,00 mm	-	53	65	1445640	CQM	W	○
60,30 x 2,00 mm	-	39	90	1445760	CQM	W	●
60,30 x 2,00 mm <sup>4</sup>	-	-	-	1445760K	CQM	W	○
76,10 x 2,00 mm	1,074	29	110	1445840L	CQM	W	○
76,10 x 2,00 mm <sup>4</sup>	-	-	-	1445840K	CQM	W	○
88,90 x 2,00 mm <sup>4</sup>	1,490	-	86	1445850K	CQM	W	○
88,90 x 2,30 mm	-	28	130	1445851	CQM	W	●
114,30 x 2,00 mm <sup>4</sup>	2,357	-	-	1446030K	CQM	W	○
114,30 x 2,30 mm	-	-	160	1446060	CQM	W	○

<sup>1)</sup> Maximum operating pressure at maximum 20 C° according to EN 13480-3 <sup>2)</sup> Execution: S = Manufactured from seamless tubes W = Manufactured from welded tubes  
<sup>3)</sup> ● = Stock standard product, ○ = Made to order <sup>4)</sup> No straight ends for orbital welding

# CALAMO – CQM MEDICAL – UNEQUAL TEE

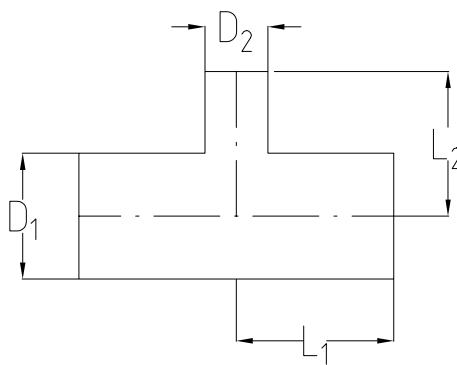

(D1) x wall (mm)	(D2) x wall (mm)	Weight (Kg/m)	Pressure <sup>1</sup> (Bar)	(L1) Length (mm)	(L2) Length (mm)	Article number	Product name	Execution <sup>2</sup> S/W	Stock <sup>3</sup> ○ / ●
15,00 x 1,00 mm	10,00 x 1,00 mm	-	-	56	56	-	CQM	S	○
15,00 x 1,00 mm	12,00 x 1,00 mm	0,054	68	56	56	-	CQM	S	○
18,00 x 1,50 mm	6,00 x 1,00 mm	0,079	-	56	56	-	CQM	S	○
18,00 x 1,50 mm	6,00 x 1,00 mm	0,079	185	35	35	-	CQM	S	○
18,00 x 1,50 mm	12,00x1,00 mm	0,086	130	59	59	-	CQM	S	○
18,00 x 1,50 mm	15,00 x 1,00 mm	-	-	-	-	-	CQM	S	○
22,00 x 1,50 mm	12,00 x 1,00 mm	0,107	86	64	46	-	CQM	S	○
22,00 x 1,50 mm	15,00 x 1,00 mm	0,111	75	64	64	-	CQM	S	○
22,00 x 1,50 mm	18,00 x 1,50 mm	0,125	91	64	64	-	CQM	S	○
28,00 x 1,50 mm	12,00 x 1,00 mm	0,140	93	64	64	1405344L	CQM	S	○
28,00 x 1,50 mm	18,00 x 1,50 mm	0,157	95	64	64	1405347L	CQM	S	○
35,00 x 1,50 mm	15,00 x 1,00 mm	0,188	-	68	68	-	CQM	S	○
35,00 x 1,50 mm	18,00 x 1,50 mm	0,201	80	68	68	-	CQM	S	○
35,00 x 1,50 mm	22,00 x 1,50 mm	0,188	-	68	68	-	CQM	S	○

<sup>1</sup>) Maximum operating pressure at maximum 20 C° according to EN 13480-3 <sup>2</sup>) Execution: S = Manufactured from seamless tubes W = Manufactured from welded tubes  
<sup>3</sup>) ● = Stock standard product, ○ = Made to order

# CALAMO – CQM MEDICAL – UNEQUAL TEE

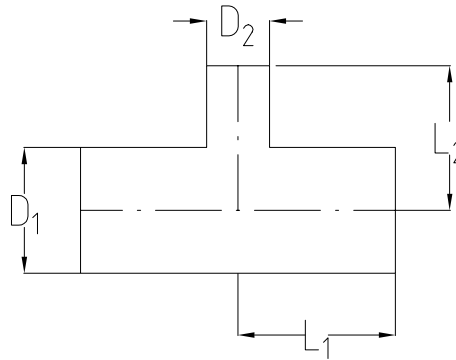

(D1) x wall (mm)	(D2) x wall (mm)	Weight (Kg/m)	Pressure <sup>1</sup> (Bar)	(L1) Length (mm)	(L2) Length (mm)	Article number	Product name	Execution <sup>2</sup> S/W	Stock <sup>3</sup> ○ / ●
48,30 x 2,00 mm	42,40 x 2,00 mm	-	-	-	-	-	CQM	W	○
60,30 x 2,00 mm	42,40 x 2,00 mm	-	-	-	-	-	CQM	W	○
60,30 x 2,00 mm	48,30 x 2,00 mm	-	-	-	-	-	CQM	W	○
76,10 x 2,00 mm	42,40 x 2,00 mm	0,953	42	-	-	1445841L	CQM	W	○
76,10 x 2,00 mm	48,30 x 2,00 mm	-	-	-	-	-	CQM	W	○
88,90 x 2,30 mm	48,30 x 2,00 mm	-	-	-	-	1445852	CQM	W	○
88,90 x 2,30 mm	60,30 x 2,00 mm	-	-	-	-	1445853	CQM	W	○
88,90 x 2,30 mm	76,10 x 2,00 mm	1,190	-	-	-	1445855	CQM	W	○
114,30 x 2,30 mm	60,30 x 2,00 mm	-	-	-	-	-	CQM	W	○
114,30 x 2,30 mm	76,10 x 2,00 mm	2,162	-	-	-	-	CQM	W	○
114,30 x 2,30 mm	88,90 x 2,30 mm	2,227	-	-	-	-	CQM	W	○

<sup>1)</sup> Maximum operating pressure at maximum 20 C° according to EN 13480-3 <sup>2)</sup> Execution: S = Manufactured from seamless tubes W = Manufactured from welded tubes  
<sup>3)</sup> ● = Stock standard product, ○ = Made to order

# CALAMO – CQM MEDICAL - CONCENTRIC REDUCER

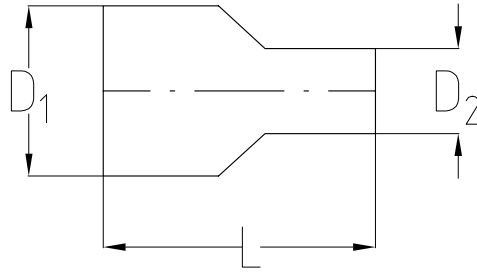

(D1) x wall (mm)	(D2) x wall (mm)	Weight (Kg/m)	Pressure <sup>1</sup> (Bar)	(L1) Length (mm)	Article number	Product name	Execution <sup>2</sup> B/P	Stock <sup>3</sup> ○ / ●
8,00 x 1,00 mm	6,00 x 1,00 mm	-	-	-	-	CQM	B	- <sup>4</sup>
10,00 x 1,00 mm	6,00 x 1,00 mm	-	221	-	-	CQM	B	- <sup>4</sup>
10,00 x 1,00 mm	8,00 x 1,00 mm	-	-	-	-	CQM	B	- <sup>4</sup>
12,00 x 1,00 mm	6,00 x 1,00 mm	0,050	176	75	-	CQM	B	○
12,00 x 1,00 mm	8,00 x 1,00 mm	-	-	-	-	CQM	B	- <sup>4</sup>
12,00 x 1,00 mm	10,00 x 1,00 mm	-	-	-	-	CQM	B	- <sup>4</sup>
15,00 x 1,00 mm	6,00 x 1,00 mm	-	-	-	-	CQM	B	- <sup>4</sup>
15,00 x 1,00 mm	10,00 x 1,00 mm	-	-	-	-	CQM	B	- <sup>4</sup>
15,00 x 1,00 mm	12,00 x 1,00 mm	-	167	-	-	CQM	B	○
18,00 x 1,50 mm	6,00 x 1,00 mm	0,100	107	75	-	CQM	B	- <sup>4</sup>
18,00 x 1,50 mm	8,00 x 1,00 mm	-	-	-	-	CQM	B	- <sup>4</sup>
18,00 x 1,50 mm	10,00 x 1,00 mm	-	-	-	-	CQM	B	- <sup>4</sup>
18,00 x 1,50 mm	12,00x1,00 mm	0,100	119	75	-	CQM	B	○
18,00 x 1,50 mm	15,00 x 1,00 mm	0,100	-	75	-	CQM	B	- <sup>4</sup>
22,00 x 1,50 mm	12,00 x 1,00 mm	-	-	-	1407983	CQM	B	- <sup>4</sup>
22,00 x 1,50 mm	15,00 x 1,00 mm	0,100	-	75	1407988	CQM	B	- <sup>4</sup>
22,00 x 1,50 mm	18,00 x 1,50 mm	-	-	-	1407990	CQM	B	○
28,00 x 1,50 mm	12,00 x 1,00 mm	0,100	61	75	1408313	CQM	B	○
28,00 x 1,50 mm	18,00 x 1,50 mm	0,100	104	75	-	CQM	B	○
35,00 x 1,50 mm	15,00 x 1,00 mm	-	-	-	-	CQM	B	- <sup>4</sup>
35,00 x 1,50 mm	18,00 x 1,50 mm	-	-	-	-	CQM	B	- <sup>4</sup>
35,00 x 1,50 mm	22,00 x 1,50 mm	-	-	-	-	CQM	B	- <sup>4</sup>

<sup>1)</sup> Maximum operating pressure at maximum 20 C° according to EN 13480-3 <sup>2)</sup> B = Manufactured from solid bar, P = Pressed plat  
<sup>3)</sup> ● = Stock standard product, ○ = Made to order <sup>4)</sup> Special request

# CALAMO – CQM MEDICAL – CONCENTRIC REDUCER

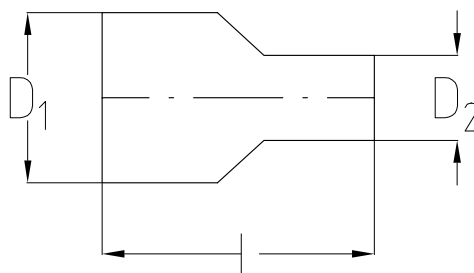

(D1) x wall (mm)	(D2) x wall (mm)	Weight (Kg/m)	Pressure <sup>1</sup> (Bar)	(L1) Length (mm)	Article number	Product name	Execution <sup>2</sup> B/P	Stock <sup>3</sup> ○ / ●
42,40 x 2,00 mm	28,00 x 1,50 mm	-	-	-	-	CQM	B/P	- <sup>4</sup>
42,40 x 2,00 mm	35,00 x 1,50 mm	-	-	-	1448575	CQM	B/P	- <sup>4</sup>
48,30 x 2,00 mm	28,00 x 1,50 mm	-	-	-	-	CQM	B/P	- <sup>4</sup>
48,30 x 2,00 mm	35,00 x 1,50 mm	-	-	-	-	CQM	B/P	- <sup>4</sup>
48,30 x 2,00 mm	42,40 x 2,00 mm	-	-	-	1448665	CQM	B/P	- <sup>4</sup>
76,10 x 2,00 mm	42,40 x 2,00 mm	-	-	-	-	CQM	B/P	- <sup>4</sup>
76,10 x 2,00 mm	48,30 x 2,00 mm	-	-	-	-	CQM	B/P	- <sup>4</sup>
88,90 x 2,00 mm <sup>5</sup>	48,30 x 2,00 mm	-	-	-	1448907K	CQM	P	- <sup>4</sup>
88,90 x 2,30 mm	48,30 x 2,00 mm	-	-	-	-	CQM	B	- <sup>4</sup>
88,90 x 2,00 mm <sup>5</sup>	76,10 x 2,00 mm	-	-	-	1448915K	CQM	P	- <sup>4</sup>
88,90 x 2,30 mm	76,10 x 2,00 mm	-	-	-	1448916	CQM	B	- <sup>4</sup>
114,30 x 2,00 mm <sup>5</sup>	76,10 x 2,00 mm	-	-	-	-	CQM	P	- <sup>4</sup>
114,30 x 2,30 mm	76,10 x 2,00 mm	-	-	-	-	CQM	B	- <sup>4</sup>
114,30 x 2,00 mm <sup>5</sup>	88,90 x 2,00 mm	-	-	-	-	CQM	P	- <sup>4</sup>
114,30 x 2,30 mm	88,90 x 2,30 mm	-	-	-	-	CQM	B	- <sup>4</sup>

<sup>1</sup> Maximum operating pressure at maximum 20 C° according to EN 13480-3 <sup>2</sup> B = Manufactured from solid bar, P = Manufactured from pressed plate  
<sup>3</sup> ● = Stock standard product, ○ = Made to order <sup>4</sup> Special request <sup>5</sup> No straight ends for orbital welding

# CALAMO – CQM MEDICAL – END CAP

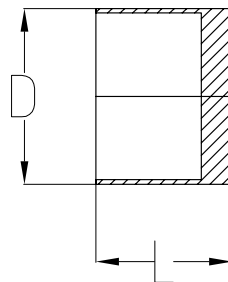

(D) x wall (mm)	Weight (Kg/m)	Pressure <sup>1</sup> (Bar)	(L1) Length (mm)	Article number	Product name	Execution <sup>2</sup> B/P	Stock <sup>3</sup> ○ / ●
6,00 x 1,00 mm	-	-	-	-	CQM	B	○
8,00 x 1,00 mm	-	-	-	-	CQM	B	○
10,00 x 1,00 mm	-	-	-	-	CQM	B	○
12,00 x 1,00 mm	-	-	-	-	CQM	B	○
15,00 x 1,00 mm	-	-	-	-	CQM	B	○
18,00 x 1,50 mm	-	-	-	-	CQM	B	○
22,00 x 1,50 mm	-	-	-	-	CQM	B	○
28,00 x 1,50 mm	-	-	-	-	CQM	B	○
35,00 x 1,50 mm	-	-	-	-	CQM	B	○
42,40 x 2,00 mm	-	-	-	-	CQM	B	○
48,30 x 2,00 mm	-	-	-	-	CQM	B	○
60,30 x 2,00 mm	-	-	-	-	CQM	B	○
76,10 x 2,00 mm	-	-	-	-	CQM	B	○
88,90 x 2,00 mm	-	-	-	-	CQM	B	○
114,30 x 2,00 mm	-	-	-	-	CQM	B	○

<sup>1)</sup> Maximum operating pressure at maximum 20 C° according to EN 13480-3 <sup>2)</sup> B = Manufactured from solid bar, P = Manufactured from pressed plate

<sup>3)</sup> ● = Stock standard product, ○ = Made to order

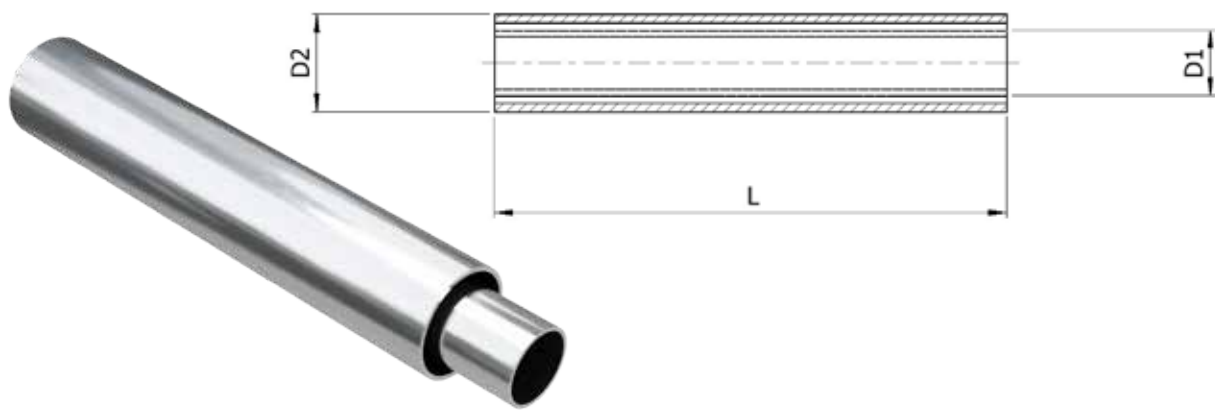

## COAXIAL TUBES

For safe transport of explosive, poisonous, corrosive and flammable gases. The coaxial tubing consists of an inner process tube and an outer safety tube. Standard option consists of an inside electropolished inner process tube and a washed outer safety tube. Both inner and outer tubes are prepared for orbital welding. Other product qualities can be delivered upon request.

(L) Nominal length 6 000 mm for execution S

(L) Nominal length 6 100 mm for execution W

DN	(D1) x wall (mm)	(D2) x wall (mm)	Weight (Kg/m)	Pressure <sup>1</sup> (Bar)	Article number	Product name	Execution <sup>2</sup> S/W	Stock <sup>3</sup> ○ / ●
8-15	6,35 x 0,89 mm	12,7 x 1,24 mm	-	221	2000120	PQE-CQ	S	○
-	9,53 x 0,89 mm	15,88 x 1,24 mm	-	208	2000280	PQE-CQ	S	○
15-20	12,7 x 1,24 mm	19,05 x 1,24 mm	-	172	2000560	PQE-CQ	S	○
15-20	12,7 x 1,24 mm	19,05 x 1,65 mm	-	194	2000562	PQE-CQ	S	○
20-25	19,05 x 1,24 mm	25,4 x 1,65 mm	-	182	-	PQE-CQ	S	○
20-25	19,05 x 1,65 mm	25,4 x 1,65 mm	-	182	2000890	PQE-CQ	S-W	○
25-40	25,4 x 1,65 mm	38,1 x 1,65 mm	-	93	-	PQE-CQ	S-W	○

<sup>1)</sup> Maximum operating pressure at maximum 20 C° according to EN 13480-3 <sup>2)</sup> Execution: S = Manufactured from seamless tubes W = Manufactured from welded tubes

<sup>3)</sup> ● = Stock standard product, ○ = Made to order



Thanks to high quality products, meticulous documentation and material traceability in place, Calamo was the first approved European supplier of high purity tubular products to the No.1 world microprocessor manufacturer. Our chemists and high qualified specialists, continuously develop new solutions to help our customers becoming better. In spacious and technically advanced facilities, we create stable and high quality products.



Follow us on [calamo.se/en/](https://calamo.se/en/)



Follow us on LinkedIn

**Calamo**  
ADDING PERFECTION

Box 6, 655 02, Molkom, Sweden  
Prostgårdsvägen 2, 655 60 Molkom, Sweden  
+46 553 313 01  
[sales@calamo.se](mailto:sales@calamo.se)  
[calamo.se/en/](https://calamo.se/en/)